

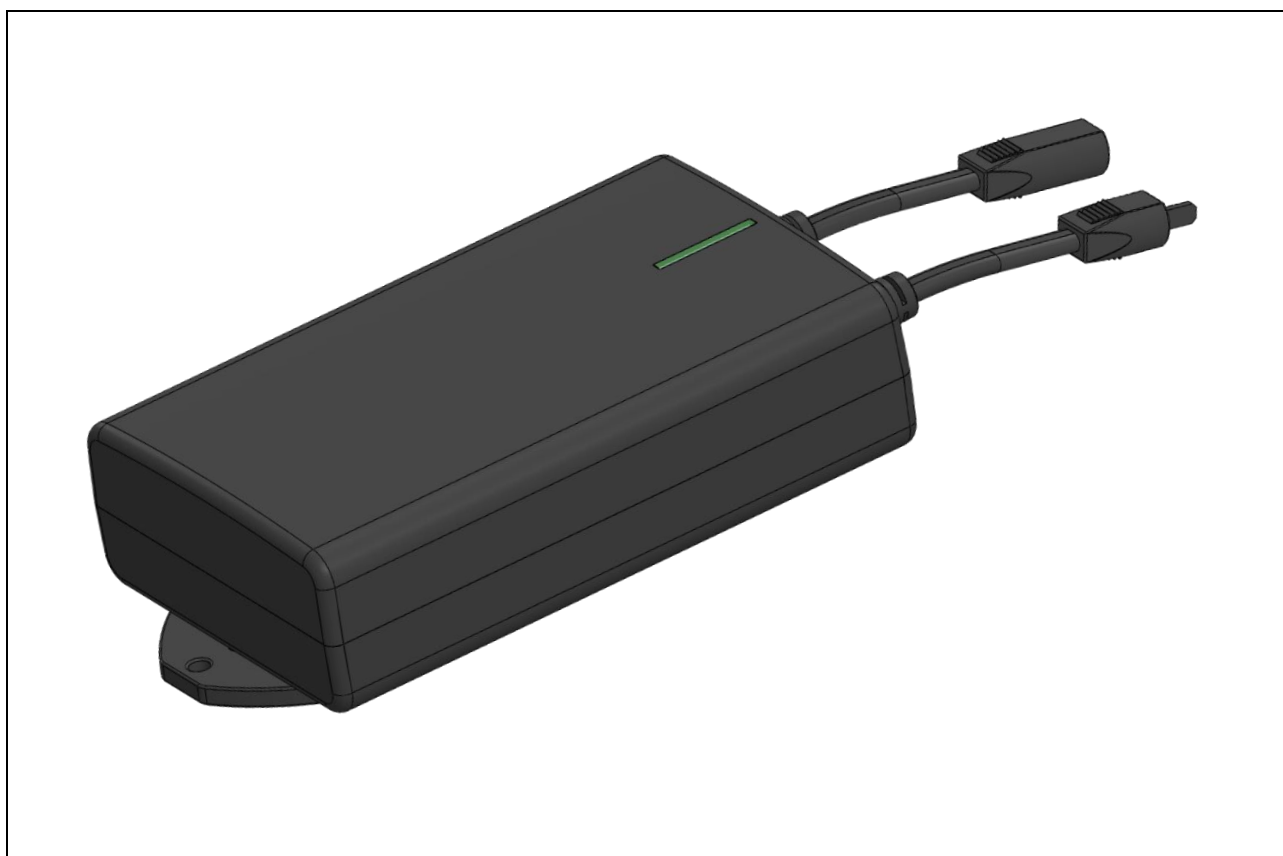

A Phoenix Mecano Brand



POWER PACK 1800

Installation Instruction

(Original installation instruction, translation)

Foreword

Revisions

Version	Date	Changes
1.0	12/2017	
2.0	01/2020	Ratings plate, Mountings plate, EU Declaration of Conformity adjusted

Disclaimer and exclusion of liability

DewertOkin is not responsible for damage resulting from:

- failure to observe these instructions,
 - changes made to this product which have not been approved by DewertOkin, or
 - the use of replacement parts which have not been approved or manufactured by DewertOkin.
- We reserve the right to make unannounced technical changes in the course of our continual product improvement process!

Creation of a complete operating instruction manual for the entire end product

These instructions are only intended to be used by the end-product manufacturer. They should not be given to the operator of the end product. The factual information contained within may be used as a basis when creating the end-product manual.

The warning and danger notices are best suited for use in the end product's manual. However it is not sufficient to simply follow these notices. You should also carry out an internal risk assessment for your end product. This can then be used as the basis for the safety notices in your manual.

These installation instructions do not contain all information required to safely operate the end product. They only describe the installation and operation of the product as partially completed machinery.

The instructions are intended for the technicians responsible for manufacturing an end product and not for the operators of the end product.

Table of Contents

Foreword	2
Revisions	2
Disclaimer and exclusion of liability	2
Creation of a complete operating instruction manual for the entire end product	2
Table of Contents	3
General	4
Conventions used	4
Warranty	4
Selection and qualification of personnel	4
Safety notices	5
Product identification	6
Description	7
Dimensions	8
Connection	10
Notes for packaging and transport	11
Storage	12
Charging periods during storage	12
Operation	13
Ambient conditions for operation, storage and transport	13
Charging the battery	14
Commissioning	14
Notes for operation	15
Acoustic warning signal	15
Deep-discharge protection	15
Optical charge level indicator	15
Cleaning and care	16
Disposal	16
Troubleshooting	16
EU Declaration of Conformity	17

General

The manufacturer of the end product must create an operating manual for that end product. The contents and especially the safety notices found in this document can be used in the operating instructions for the end product.



Read attentively and follow this information carefully before handling the rechargeable batteries. Keep this document in a safe place.



Be sure to follow the notices and information found on the battery and packaging.

Conventions used

Notices which do not relate to safety are indicated in these instructions with a triangle:

- ▶ Triangular notice symbol

Safety notice explanations



CAUTION

CAUTION against dangerous situation, risk of injury.

NOTICE

NOTICE is used to address practices which are not related to personal injury but may result in damage to the product or surroundings.

Warranty

Rechargeable batteries, by their nature, have a limited lifespan and are characterized by gradual power loss over time. The normal depreciation and continual power loss exhibited by the battery are not covered by any warranty claims.

Selection and qualification of personnel

The installation of the POWER PACK 1800 in the end product may only be performed by qualified personnel.

Safety notices



CAUTION

Leaking batteries present a health hazard!

- Leaking battery fluid can injure your skin or eyes.
- The fluid is harmful when touched or swallowed.
- If you come into contact with battery fluid, clean the affected area with water and contact a doctor.



CAUTION

- If the housing or cable are damaged, the battery must be disposed immediately.
- Do not open or destroy the battery.
- Do not solder or weld at the battery or in the vicinity of the battery.
- Avoid contact with water.
- Use only by DewertOkin approved Chargers.

The POWER PACK 1800 should not be used:

- in any environment where combustible or explosive gases or vapours (e.g., anaesthesiology) may be present,
- in the proximity of open fires or other heat sources (such as furnaces, ovens or direct sunlight),
- in any application that will be cleaned with an automated washing system,
- in a moist environment,
- outdoors,
- as a power source for toys or games.

The POWER PACK 1800 can be used by children of 8 years and older, persons with reduced physical, sensory or mental capabilities, or persons with lack of experience or knowledge when they are supervised or instructed concerning the safe use of the device and when they understand the resulting risks. Do not allow children to play with this device. The cleaning and user maintenance must not be carried out by children without supervision.

NOTICE

- Improper storage can reduce the performance of your battery or destroy it.

Product identification

A ratings plate on each product specifies the exact name and serial number of the product. It also states the technical specifications valid for that particular product.

- ▶ The ratings plate shown is an example; the specifications for your product may differ from this illustration.

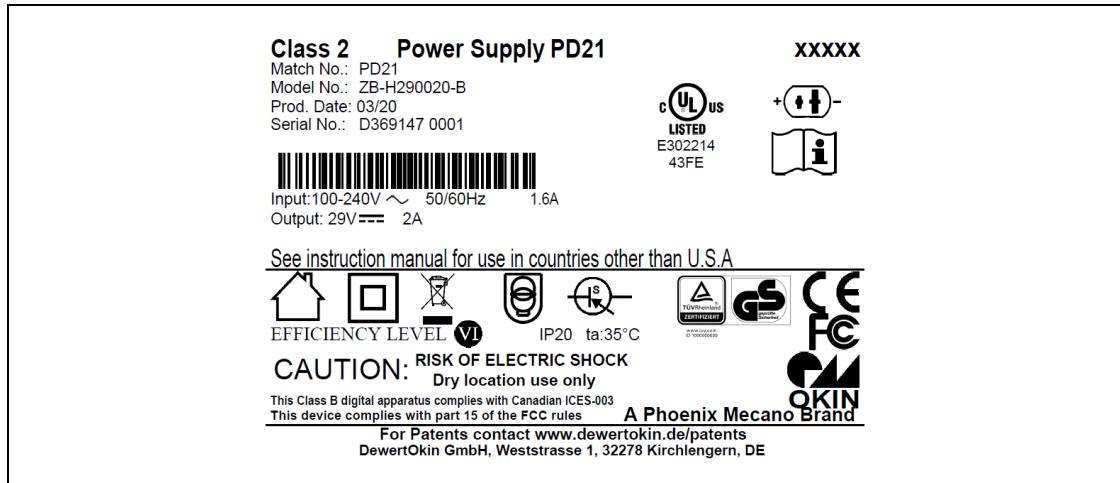

Fig. 1: Ratings plate Power Supply PD21 (example)

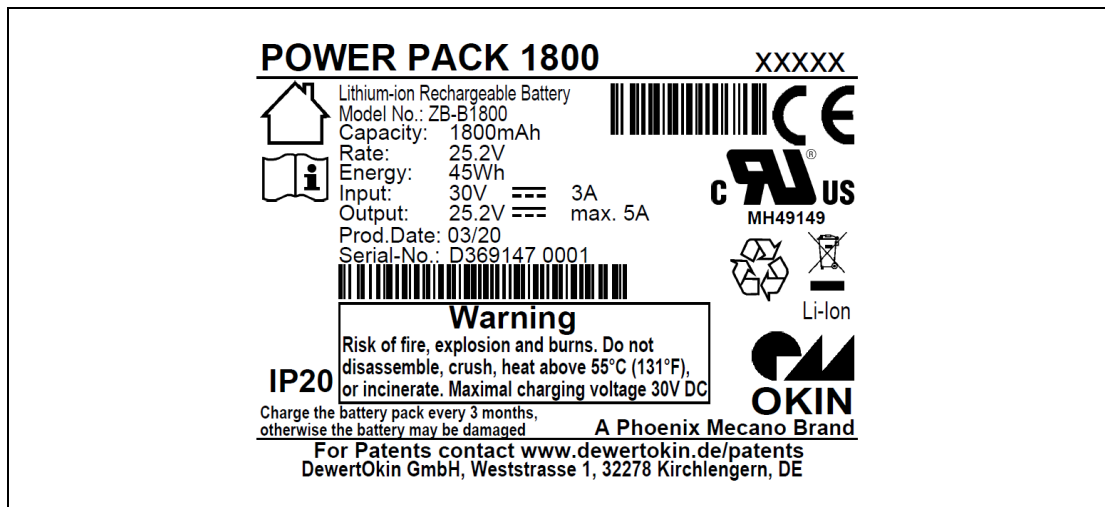

Fig. 2: Ratings plate POWER PACK 1800 (example)

Description

POWER PACK 1800

The POWER PACK 1800 serves for mains independent power supply of electro motorical adjustable applications. The POWER PACK 1800 has the following special features:

- The POWER PACK 1800 is used as a power supply at power failure.
- ▶ We reserve the right to make unannounced technical changes in the course of our continual product improvement process!

To charge the POWER PACK 1800 the POWER SUPPLY PD21 with the appropriate country version is necessary.

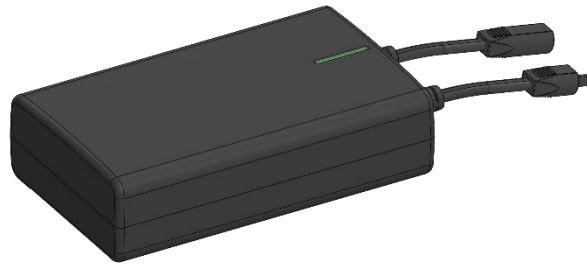

Fig. 03: POWER PACK 1800

Important Features

- Very low self-discharge rate
- Short circuit proof
- Overcurrent switch off
- Deep-discharge protection
- Acoustic warning signal for low remaining charge
- Optical charge level indicator
- LED charge indicator: LED lights red – Accu is charging
LED lights green – Accu is fully charged
- Mounting plates

Technical data

- Lithium-Ion Accu (li-Ion)
- Capacity: 1800 mAh
- Energy: 45 Wh
- max. voltage 30 V DC
- Output voltage: 25.2 V DC
- max. output current 5 A
- Acoustic signal: ≤ 23 V
- Temperature range 0 °C – 40 °C
- Charging time approx. 5 - 8 h (depending on charging state)
- Low weight: approx. 550 g
- approx. 300 charging cycles (depending on usage and operational conditions)

Power Supply PD21

Input: 100-240V AC, 50-60 Hz , 1,6 A

Output: 29 V DC, 2 A

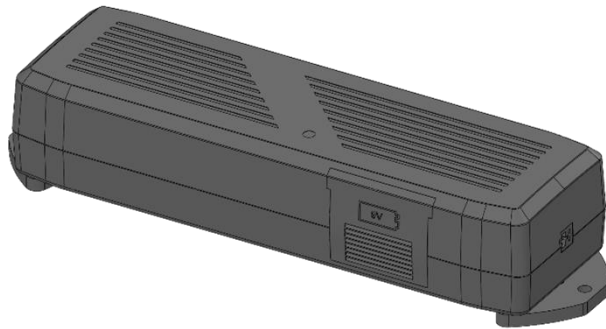

Fig. 04: Power Supply PD21

Warning:

For charging the POWER PACK 1800 must be used PD21 POWER SUPPLY!

Dimensions

POWER PACK 1800

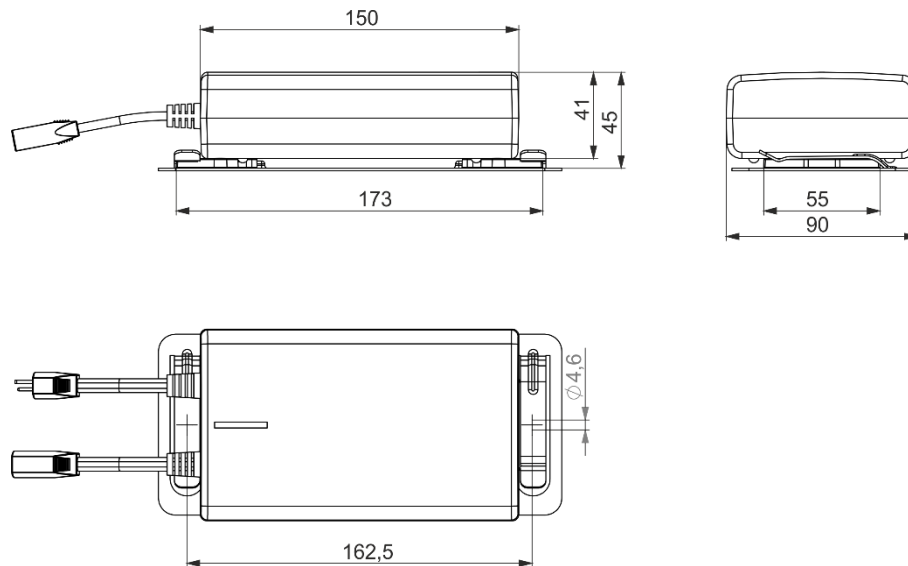
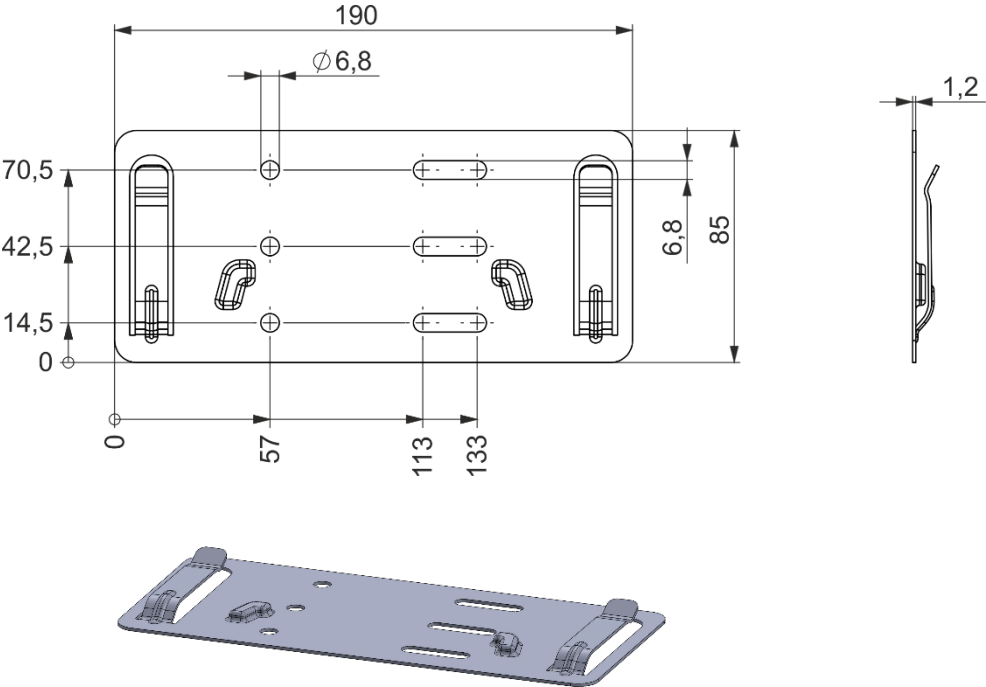

Fig. 05: Dimensions of POWER PACK 1800

Mounting plate (options)

1)



Connection

As standard the POWER PACK 1300 is charged as needed with the PD21 POWER SUPPLY

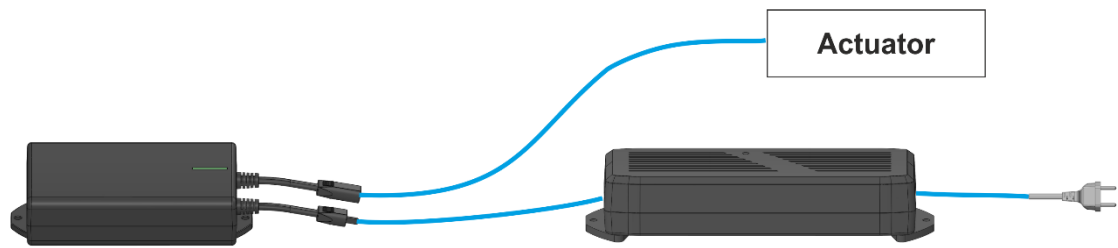

Fig. 06: Overview of charging

NOTICE

Should the POWER PACK 1800 be used in combination with operating elements that have a power consumption at rest, such as touch sensors, RF-systems or Bluetooth-adapters it perhaps must be charged more frequently.

Please contact your supplier/dealer!

Notes for packaging and transport



CAUTION

Damaged POWER PACK 1800

A damaged POWER PACK 1800 must not be connected or taken into operation. Please contact your sales partner/supplier immediately!

The POWER PACK 1300 is shipped ex works according to the applicable packaging regulations. Take care when transporting, that the risk of falling or slipping is avoided. Before unpacking, check the secondary packaging for damages.

To prevent injury please follow the safety instructions given in chapter 2, before you unpack your product.

If the packaging is damaged or you note a damage after unpacking, please immediately report.

In case of product return the following notes need to be observed:

When transporting Li-ion storage batteries the current regulations according to ADR for road transport and/or IATA for air shipping must be observed.

Damaged storage batteries must be assessed case by case with respect to safe transport.

Please contact your sales dealer/supplier.

➡ Please consider the disposal notes in chapter „disposal“.

Storage



CAUTION

The battery should be stored so that the battery terminals cannot short circuit each other and so the terminals cannot be short circuited by any metal surroundings.

NOTICE

Rechargeable batteries must be charged at least six months after their production date or charged immediately upon delivery and then after six months of storage. For some drive systems, a minimal level of current may flow even when the drive is not being used. After a prolonged period this can lead to a low charge status.

If the POWER PACK 1300 is discharged and not in use for a long time it can be damaged.

NOTICE

The battery may not be connected to a drive system or control unit in delivery or storage condition!

The connection cable for the battery should be disconnected from the control unit or drive as well as from mains supply if you are not planning to use the drive system for an extended period. It should then be reconnected before you plan to use the system. This will prevent the battery from losing its charge in certain applications.



Do not store in direct sunlight.

Charging periods during storage

NOTICE

Following longer periods of storage, the batteries may need to be charged and discharged several times so that performance reaches a peak.

Operation

Type of check / action	Explanation	Time interval
Recharging	To maintain battery performance	No longer than six months after date of manufacture.
Recharging during storage	Recharge during storage to maintain battery performance capability	At least every six months.

Ambient conditions for operation, storage and transport

Transport / storage temperature: from 0°C to +55°C

Operating temperature: from 0°C to +40°C

Relative humidity: from 20% to 85%

Charging the battery

NOTICE

Due to the chemical reactions the POWER PACK 1800 warms-up during charging.

If the POWER PACK 1800 should become really hot, the protective circuit is defective. In this case remove all connection cables of the drive / control unit and check the unit (POWER PACK 1800 and PD21 POWER SUPPLY) by an authorized technician or producer.

Do not set up the POWER PACK 1800 in bath- or shower rooms. The charger is not splash proof.

Only recharge the POWER PACK 1800 at the temperatures given below:

Charging temperature: from +10°C to + 40°C

The POWER PACK 1800 deliver their full capacity after 5-10 charge and discharge cycles.

Exclusively use the PD21 POWER SUPPLY for charging the POWER PACK 1800 and make your-self familiar with the operation of the device.

Charging time of the POWER PACK 1800 may take approx. 5 - 8 h.

The red LED flashes during the charging process. When the battery is fully charged, the electronics switch to standby and the LED lights green. The green LED switches off after the PD21 POWER SUPPLY has been disconnected from the POWER PACK 1800.

A green LED on the PD21 POWER SUPPLY indicates that it is connected to a power supply.

The system can be operated/moved while it is being charged.

Commissioning

NOTICE

Charge the POWER PACK 1800 completely before first use. This is necessary so that the maximum capacity can be reached. When the green LED switches off, the POWER PACK 1800 is fully charged. The maximum battery capacity is now available.

NOTICE

Electrical components should be connected or disconnected only when the power supply cord is unplugged.

The POWER PACK 1800 can then perform optimally when the product is being used at normal room temperatures from 18 °C to 25 °C. The operating temperature should never exceed 40 °C.

The acoustic low battery-warning built-in to the POWER PACK 1800 is only active when the drive is moving!

It is possible that after long periods of storage, several cycles of charging and re-charging may be required to restore the performance of the POWER PACK 100.

Connect the POWER PACK 1800 to the PD21 POWER SUPPLY ensuring the correct connection port is used. The plug should fit securely in place.

Connect the PD21 POWER SUPPLY to the socket. During charging lights the LED **red**. If the charging cycle is complete and the PD21 POWER SUPPLY is disconnect from the socket the LED goes out.

Notes for operation

NOTICE

If you not use the drive system for an extended period, disconnect the POWER PACK 1800 from the control unit/drive system as well as from the mains supply. It should then be re-connected if you plan to use the system. This will prevent the battery from losing its charge in certain applications.

Acoustic warning signal

An acoustic warning signal indicates that the battery charge state is very low. The POWER PACK 1800 must be charged.

Deep-discharge protection

The switch-off voltage of the POWER PACK 1800 is ≤ 22 V. If the actual voltage falls below this level, the POWER PACK 1800 is disconnected from the system. If the battery voltage rises back up over the switch-off level, then it will switch on again. Otherwise, the POWER PACK 1800 will remain switched off.

Optical charge level indicator

Red LED:

If the charger is connected correctly, the red LED flashes and the POWER PACK 1800 charges. If the LED does not light up, check the connections. There may be a disconnection or malfunction.

Green LED:

The green LED switches on when the POWER PACK 1800 is charged. It switches off when the POWER PACK 1800 is discharged. The charging circuit switches to standby and the LED goes out. If the battery voltage falls below a certain level, the charging process resumes and the green LED lights up.

Cleaning and care

The POWER PACK 1800 is maintenance free.

- 1 Be sure to unplug all connecting cables before you begin cleaning it!
- 2 Clean the POWER PACK 1800 as needed using a dry, antistatic cloth.
- 3 Be sure that you do not damage the connecting cables during the cleaning

NOTICE

Never clean the POWER PACK 1800 in an automated washing system or with a high-pressure cleaner. Do not allow fluids to penetrate the lighting. Damage to the system could result.

Do not use a cleanser that contains benzene, alcohol or similar solvents.

Disposal

The POWER PACK 1800 consists of electronic components, cables and metal and plastic parts. You should observe all corresponding national and regional environmental regulations when disposing of the system.

The disposal of the end product is regulated in Germany by Elektro-G, internationally by the EU Directive 2012/19/EC (WEEE), or by any applicable national laws and regulations.

The POWER PACK 1800 should not be disposed of with normal household waste!



Troubleshooting

This chapter describes troubleshooting methods for fixing problems. If you experience an error that is not listed in this table, please contact your supplier.

Problem	Possible cause	Solution
Handset or drive system without function	Handset or drive system defective	Contact your supplier/dealer
	POWER PACK 1800 is discharged	Charge the POWER PACK 1800
Drives suddenly no longer respond, no movement takes place	The unit's fuse may have been triggered	Contact your supplier/dealer
	A cable has been disconnected (mains power or handset, slave drive)	Check the cables, if necessary restore contact
	POWER PACK 1300 is discharged	Charge the POWER PACK 1300
	Overload fuse has been triggered	Stop operating the system for 5 sec. and charge the POWER PACK 1300

EG-Konformitätserklärung

Nach Anhang IV der EMV-Richtlinie 2014/30/EU

Nach Anhang IV der EU-Niederspannungsrichtlinie 2014/35/EU

Nach Anhang VI der RoHS-Richtlinie 2011/65/EU (inkl. Delegierte Richtlinie (EU) 2015/863)

Der Hersteller

EU Declaration of Conformity

In compliance with Appendix IV of the EMC-Directive 2014/30/EU

In compliance with Appendix IV of the LVD-Directive 2014/35/EU

In compliance with Appendix VI of the EU RoHS Directive 2011/65/EU (incl. Commission delegated Directive (EU) 2015/863)

The manufacturer

DewertOkin GmbH
Weststraße 1
32278 Kirchlengern
Deutschland - Germany

erklärt hiermit, dass das Produkt

declares that the following product

PCK 9F P57 ? 1800

mit DewertOkin Antriebssystem / with DewertOkin drive system
mit DewertOkin Steuerungssystem / with DewertOkin control system

die Anforderungen folgender EG-Richtlinien erfüllt:

meets the requirements of the following EU directives:

Richtlinie über elektromagnetische Verträglichkeit 2014/30/EU

Electromagnetic Compatibility Directive 2014/30/EU

Niederspannungsrichtlinie 2014/35/EU

Low Voltage Directive 2014/35/EU

DELEGIERTE RICHTLINIE (EU) 2015/863 DER KOMMISSION vom 31. März 2015 zur Änderung von Anhang II der Richtlinie 2011/65/EU des Europäischen Parlaments und des Rates hinsichtlich der Liste der Stoffe, die Beschränkungen unterliegen.

COMMISSION DELEGATED DIRECTIVE (EU) 2015/863 of 31 March 2015 amending Annex II to Directive 2011/65/EU of the European Parliament and of the Council as regards the list of restricted substances.

Angewendete Normen

Applied standards:

- EN 60950-1:2006/A1:2013
- EN 55014-1:2006/A1:2009/A2:2011
- EN 55014-2:1997/A1:2001/A2:2008
- EN 61000-3-2:2014
- EN 61000-3-3:2013
- EN 62133:2013 (POWER PACK 1800)

Konstruktive Änderungen, die Auswirkungen auf die in der Montageanleitung angegebenen technischen Daten und den bestimmungsgemäßen Gebrauch haben, das Produkt also wesentlich verändern, machen diese Konformitätserklärung ungültig!

This declaration of conformity is no longer valid if constructional changes are made which significantly change the drive system (i.e., which influence the technical specifications found in the instructions or the intended use)!



Kirchlengern, Germany 14 January 2020

Dr.-Ing. Josef G. Groß
Geschäftsführer / Managing Director

DewertOkin GmbH
Weststraße 1
32278 Kirchlengern
Tel: +49 (0)5223/979-0
Fax: +49 (0)5223/75182
<http://www.dewertokin.de>
Info@dewertokin.de

ID-No.: 88952