

OKIMAT IPS / OKIMAT IPSe / OKIMAT 2 IPS / OKIMAT EPS

Installation Instructions

(Translation of the original installation instructions)

Foreword

Disclaimer and exclusion of liability

DewertOkin is not responsible for damage resulting from:

- failure to observe these instructions,
- changes made to this product which have not been approved by DewertOkin, or
- the use of replacement parts which have not been approved or manufactured by DewertOkin.

Creation of a complete operating instruction manual for the entire end product

These instructions are only intended to be used by the end-product manufacturer. They should not be given to the operator of the end product. The factual information contained within may be used as a basis when creating the end-product manual.

The warning and danger notices are best suited for use in the end product's manual. However it is not sufficient to simply follow these notices. You should also carry out an internal risk assessment for your end product. This can then be used as the basis for the safety notices in your manual.

These installation instructions do not contain all information required to safely operate the end product. They only describe the installation and operation of the drive as partially completed machinery.

The instructions are intended for the technicians responsible for manufacturing an end product and not for the operators of the end product.

Table of contents

Foreword	3
Disclaimer and exclusion of liability	3
Creation of a complete operating instruction manual for the entire end product	3
1. General Information	5
1.1 Safety notices within the installation instruction and the operating instructions for the entire machine	5
1.2 Conventions used	6
2. Safety notices	7
2.1 Proper and intended usage	7
2.2 Selection and qualification of personnel	8
2.3 Ratings plate	9
3. Possible combinations	10
4. Description	11
4.1 Components	11
5. Technical specifications	14
6. Installation	16
6.1 Safety notices to observe during installation	16
6.2 Installation procedure	17
7. Information about creating your Operating Manual	25
7.1 General information	25
7.2 Handset / hand-held remote control	26
7.3 Notice for operating with optional configuration	28
8. Troubleshooting	30
9. Maintenance	31
9.1 Maintenance	31
9.2 Cleaning and care	31
10. Disposal	32
10.1 Packaging material	32
10.2 Drive components	32
Declaration of incorporation/installation	33
EU Declaration of Conformity	34

1. General Information

- ▶ The OKIMAT name, as used here, also includes the OKIMAT IPS, OKIMAT IPSe, OKIMAT 2 IPS and OKIMAT EPS configurations.

These installation instructions must be followed closely in order to install this drive successfully and safely in the end product. These instructions are not an operating manual for the end product.

These instructions will help you to minimize danger, repair costs and down times. They will also help you to maximize the reliability and lifespan of the end product.



CAUTION

The notices in these instructions must be followed! Following the guidelines during installation and connection procedures will help to minimize:

- the risk of accident and injury, and
- damage to the drive system or the end product.

These installation instructions have been written with due care and attention. However, we cannot guarantee that the data, images and drawings are complete and correct nor do we accept any liability for the information contained therein, unless required by law.

Availability of this document

As manufacturer of the end product, you are obligated to comply with Machinery Directive 2006/42/EC. This directive stipulates that the installation instructions must be kept on file for governmental inspection purposes.

1.1 Safety notices within the installation instruction and the operating instructions for the entire machine

The manufacturer of the complete machine (the end product) is only permitted to operate the OKIMAT drive (by itself an incomplete machine)

- when the end product (for which the OKIMAT drive is intended) is in compliance with all protective measures specified in the Machinery Directive 2006/42/EC, and
- when the manufacturer expressly declares the compliance of the end product.

The manufacturer of the end product must create a manual for the users of that product. The safety notices in the end-product manual must be written based on the end product's risk assessment.

1.2 Conventions used

Notices which do not relate to safety are indicated in these instructions with a triangle:

- ▶ Triangular notice symbol

Safety notice explanations

 CAUTION
CAUTION indicates a hazardous situation which, if not avoided, could result in minor or moderate injury.

NOTICE
NOTICE is used to address practices which are not related to personal injury but may result in damage to the product or surroundings.

2. Safety notices

2.1 Proper and intended usage

The OKIMAT drives are intended to be installed in beds.

- They provide motor adjustment capabilities for movable reclining bed parts. They should be used in conjunction with suitable brackets and mechanics.



CAUTION

Risk of accident

This drive should only be used for the applications described above. Any other use is forbidden. Improper usage can lead to accidents or destruction of the unit. Such non-approved applications will lead immediately to the expiration of all guarantee and warranty claims on the part of the end-product manufacturer against the manufacturer.

Improper usage

Be sure to follow the notices below concerning improper usage. You should include them in your product manual in order to inform the users of your end product.

The OKIMAT drives should not be used:

- in any environment where combustible or explosive gases or vapours (e.g., anaesthesiology) may be present,
- in a moist environment,
- outdoors,
- in any application that will be cleaned with an automated washing system,
- for raising and lowering loads in industrial or technical applications,
- with forces which exceed those specified on the ratings plate.

The OKIMAT drive can be used by children of 8 years and older, persons with reduced physical, sensory or mental capabilities, or persons with lack of experience or knowledge when they are supervised or instructed concerning the safe use of the device and when they understand the resulting risks. Do not allow children to play with this device. The cleaning and user maintenance must not be carried out by children without supervision.

- ▶ You should only use spare parts which have been manufactured or approved by DewertOkin. Only these parts will guarantee a sufficient level of safety.

Optional: battery-operated reset function**NOTICE**

The battery-operated reset function is not a safety system and does not avert danger.

DewertOkin does not guarantee that the drive will function in the event of a power outage.

If the end-product manufacturer chooses to guarantee the functionality of the end product during a power outage, then the end-product manufacturer is responsible for arranging a mechanism to ensure this functionality.

2.2 Selection and qualification of personnel

The installation of the drive in the end product may only be performed by qualified personnel.

2.3 Ratings plate

- ▶ The ratings plate shown is an example; the specifications for your drive may differ from this illustration.

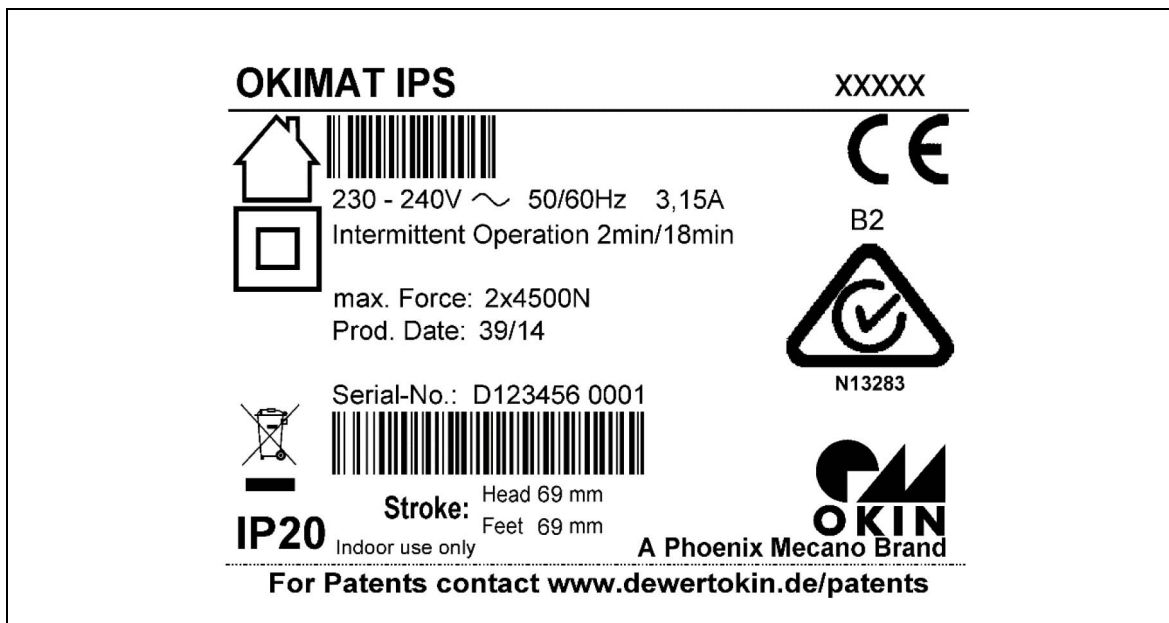





Figure 1 Ratings plate example

OKIMAT IPS	Model name
xxxxx	Article number
230 - 240V ~	Input voltage
50/60Hz	Frequency
3,15A	Current consumption
Intermittent Operation 2min/18min	Intermittent duty / power-on time
Max. Force	Push force
Prod. Date	Calendar week / year
Serial-No.	Serial number for your drive
IP20	Protection degree
Stroke	Stroke (head / foot)
	Use in dry rooms only!
	Protection class II
	Follow all special disposal instructions!
	Conformity mark

3. Possible combinations

The OKIMAT drives can be combined for use with other DewertOkin components and drives. The following basic combinations are possible:

Options for:	IPS	EPS	IPSe	2 IPS
Cable handset ¹⁾	x	x	x	x
Built-in RF receiver and RF hand-held remote control ²⁾	x		x	
External RF receiver and RF hand-held remote control ¹⁾	x	x	x	x
PowerPack 1300 ^{1), 3), 4)}	x	x	x	
UBB retro-fit ¹⁾	x	x	x	

¹⁾ Not together with OKIMAT IPS / IPSe (built-in RF)

²⁾ Not together with OKIMAT IPSe (built-in RF)

³⁾ Optional for the OKIMAT IPS and OKIMAT EPS

⁴⁾ Only together with the OKIMAT IPS / EPS without relay circuit (with direct circuit)

Systems can be customized by combining drives and OKIN controllers. The system components must be connected in a specific order. The mains plug should only be plugged in after all other components are connected.

DewertOkin has separate system instruction manuals containing all information and instructions needed for these systems.

- ▶ Only a DewertOkin device should be used to control the drive since they have already been verified to work together.

4. Description

The drives units are powered by electrical motors. The back and leg sections of a bed can be adjusted depending on the drive options. The drive is controlled by means of an OKIN controller.

The different drive models vary according to their:

- motor power,
- optional reset function,
- optional pluggable mains power cord,
- optional variant with an external switched-mode power supply (EPS),
- different stroke variants,
- integrated RF radio receiver,
- country-specific mains power plug,
- optional mains cut-off mechanism

4.1 Components

The components have a compact design – with two linear adjusting units and a control unit located within an enclosed housing. To facilitate the tool-free assembly process, the two sliders on the side (the shutters) can be removed from the housing.

 CAUTION
Risk of accident Please follow these operating instructions carefully. You could be injured by fire or electrical shock if you do not follow these assembly instructions.

The appropriate pluggable power supply cord with integrated switched-mode power supply is included, depending on the regional version (USA, continental Europe (EURO plug), the UK, Australia or Japan).

NOTICE
Only use the proper power cable that is permitted in your country. Be sure to use the correct plug adapter, as shown in the following illustration.

- ▶ There is a delay after the supply voltage is applied before the device actually turns on. Wait at least two seconds before beginning the commissioning.

 CAUTION
Risk of accident <ul style="list-style-type: none"> • Electrical components should be connected or disconnected only when the power supply cord is unplugged. • Please note that residual electrical energy can even be present in the OKIMAT (IPS, IPS IPSE and 2) when it is unplugged.

4.1.1 Option: integrated switched-mode power supply (IPS) with pluggable power supply cord

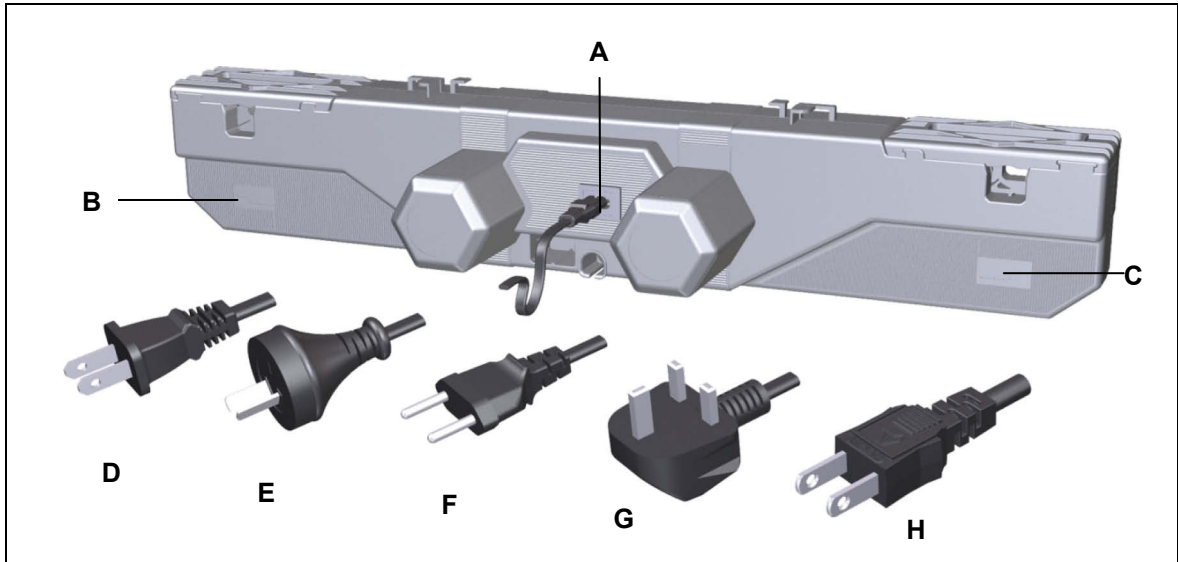

Figure 2 Variants of the OKIMAT IPS pluggable mains power cord

- | | |
|--------------------------------------|---------------------------------|
| A Mains power socket (EURO-8) | B Foot side |
| C Head side | D Power plug (USA) |
| E Power plug (Australia) | F Power plug (EURO flat) |
| G Power plug (United Kingdom) | H Power plug (Japan) |

4.1.2 Option: integrated switched-mode power supply (IPS / IPSe) with attached power supply cord

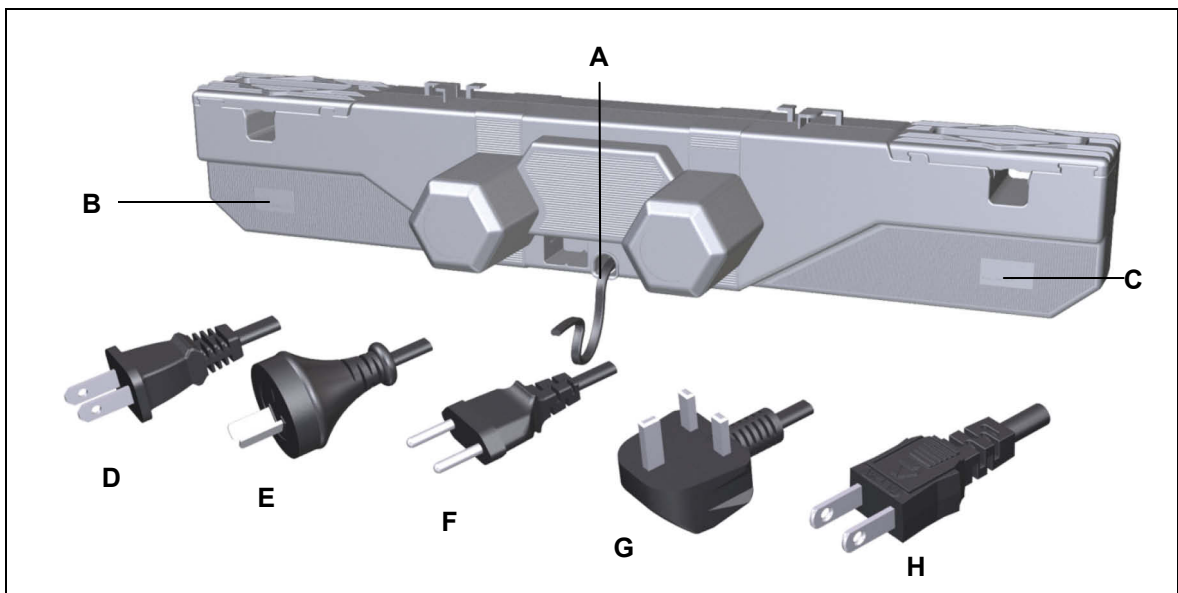

Figure 3 Variants of the OKIMAT IPSe attached mains power cord

- | | |
|--------------------------------------|---------------------------------|
| A Power cord | B Foot side |
| C Head side | D Power plug (USA) |
| E Power plug (Australia) | F Power plug (EURO flat) |
| G Power plug (United Kingdom) | H Power plug (Japan) |

4.1.3 Option: integrated switched-mode power supply (IPS) with mains cut-off

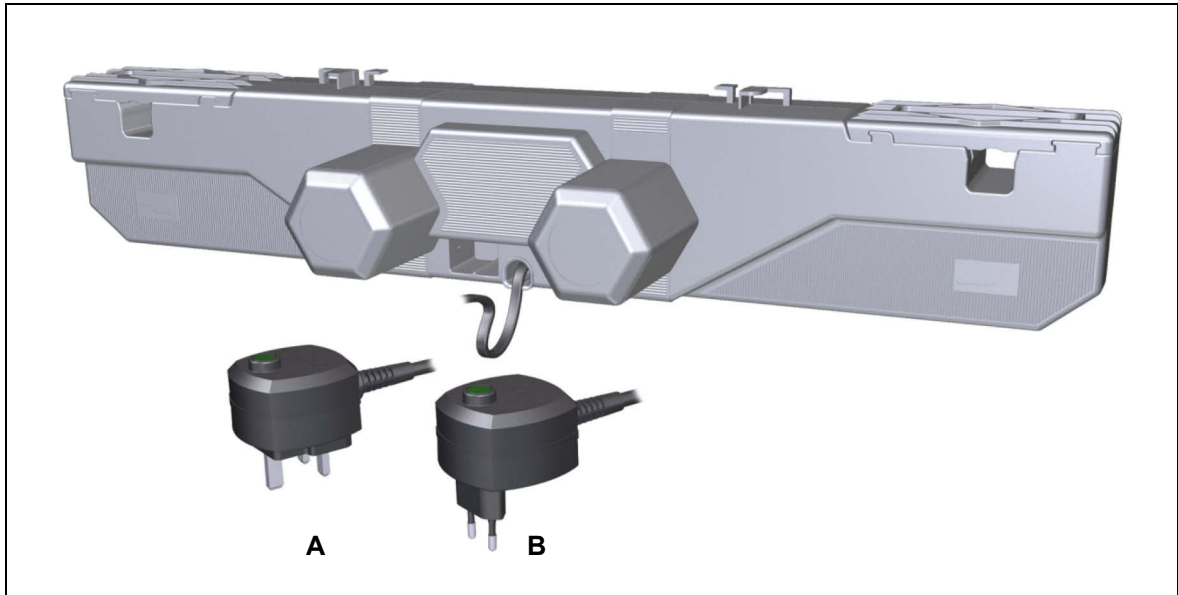

Figure 4 Variants of the attached mains cut-off on the OKIMAT IPS
A Mains cut-off (United Kingdom) B Mains cut-off (EURO)

4.1.4 Option: external switched-mode power supply (EPS)

A connection on the optional external switched-mode power supply (EPS) allows you to connect the power supply (e.g. PD12/PD13 Power Supply) using an LSP plug.

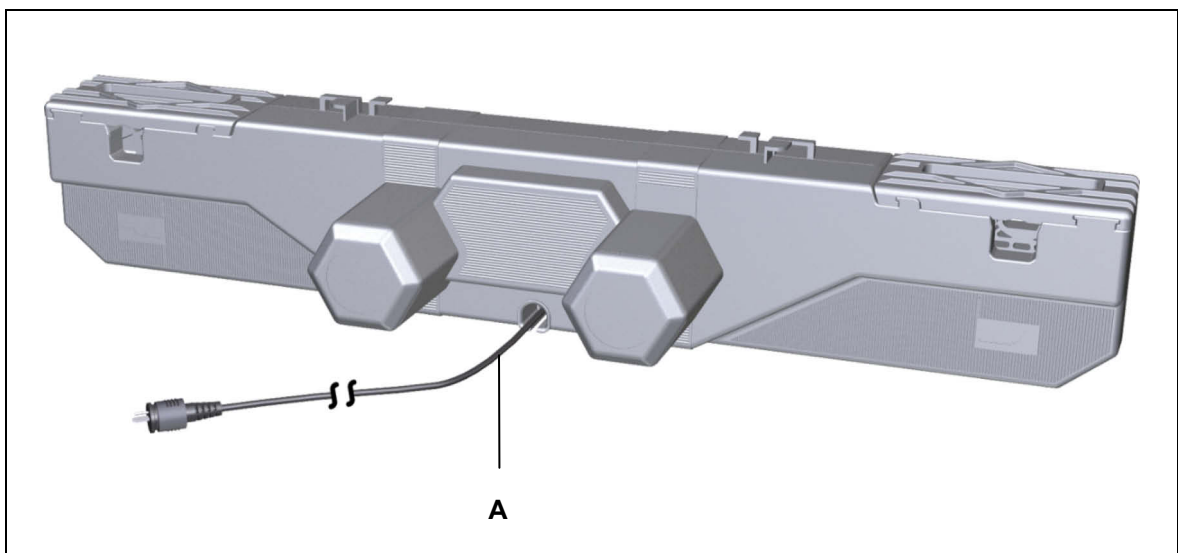

Figure 5 Variant with a connection for an external switched-mode power supply (EPS)
A Connecting cable (length of approx. 2000 mm) with LSP plug (e.g. for the PD12/PD13 power supply)

5. Technical specifications

	OKIMAT IPS	OKIMAT IPSe	OKIMAT 2 IPS	OKIMAT EPS
Connection to mains power (AC) / Input voltage (DC)	100 – 240 V, 50/60 Hz	230 – 240 V, 50/60 Hz	230 – 240 V, 50/60 Hz	24 V – 29 V
Power output	Max. 116 W			
Permitted push force ³⁾	Max. 6000 N ⁴⁾	Max. 4500 N ⁵⁾	Max. 6000 N	Max. 6000 N
Adjustment speed ³⁾	Max. 4.5 mm/s	Max. 5.5 mm/s	Max. 4.5 mm/s	Max. 4.5 mm/s
Mode of operations ¹⁾	Intermittent duty 2 min./18 min.			
Protection class	II			III
Noise level	≤ 65 dB(A)			
Drive type	Double drive			
Protection degree	IP20			
Stroke ²⁾	87, 74, 69, 54			
Length x width x height	708 mm x 166 mm x 120 mm			
Axle gap distance	581 mm (+/- 2 mm)			
Gap to pivot lever	Min. 480 mm (+ 2mm); refer to Figure 7			
Axle support diameter	Ø 25 mm, optional Ø 34 mm	Ø 25 mm	Ø 25 mm, optional Ø 34 mm	Ø 25 mm, optional Ø 34 mm
Weight	Approx. 4.1 kg	Approx. 3.7 kg	Approx. 4.1 kg	Approx. 3.9 kg
Optional: battery-operated reset function				
Voltage	One nine-volt battery (6LR61)			
Ambient conditions for operation, storage and transport				
Transport / storage temperature	From -20 °C to +50 °C From -4 °F to +122 °F			
Operating temperature	From +10 °C to +40 °C From +50 °F to +104 °F			
Relative humidity	From 30% to 75%			
Air pressure	From 800 hPa to 1060 hPa			
Height	< 2000 m			

1) Mode of operation: intermittent duty 2 min./18 min. This means that after the unit is operated with its rated load for up to two minutes it must then be paused for 18 minutes. The system can malfunction if this pause is not observed!

2) Other stroke distances are available on request.

3) Depending on model

4) When using the OKIMAT IPS with relay circuit.

5) When using the OKIMAT IPSe with integrated RF radio receiver: max. 5000 N.

Dimensions of housing

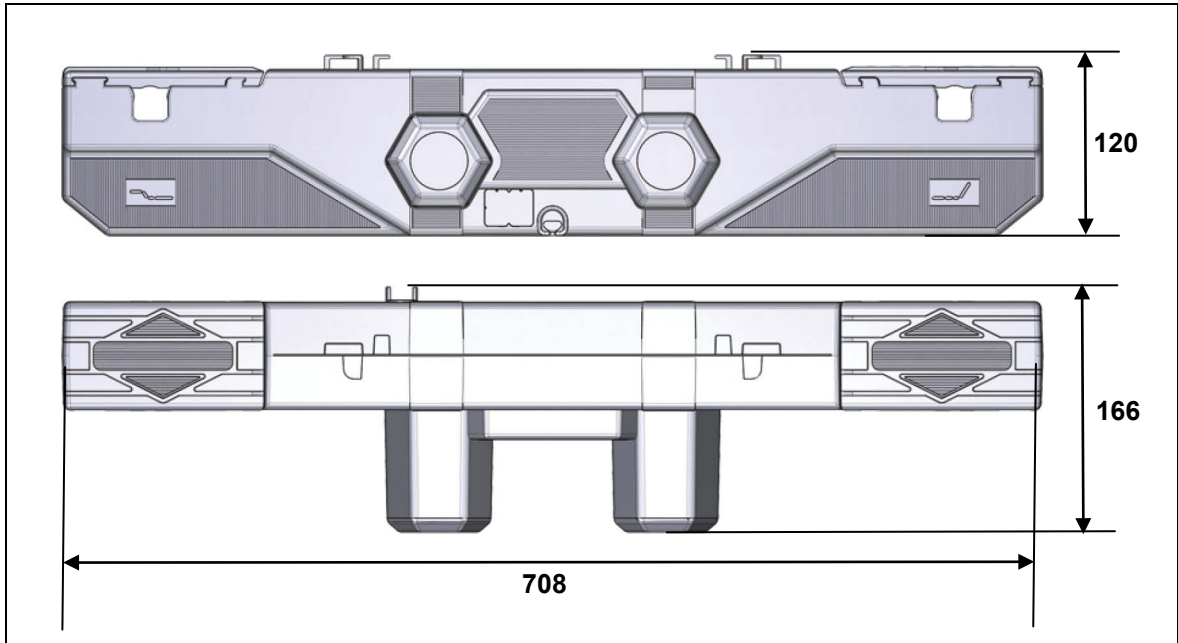

Figure 6 OKIMAT (specified in mm)

Dimensions of the pivot lever

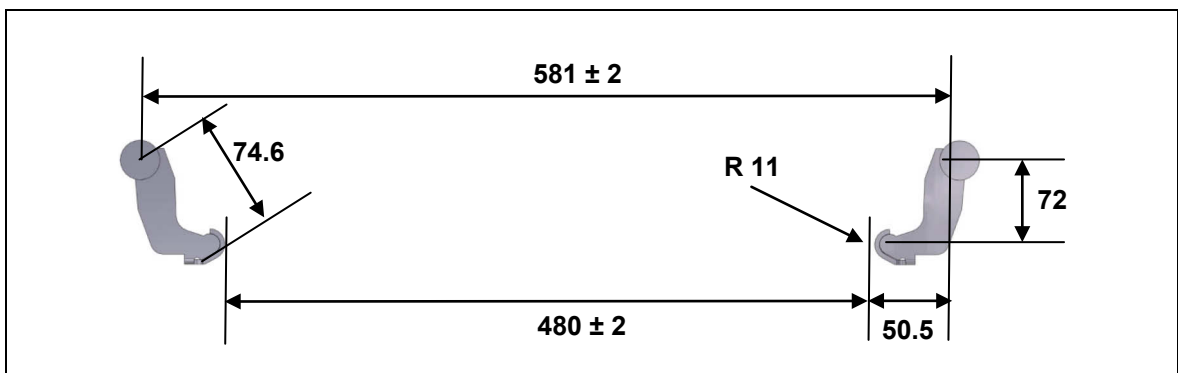

Figure 7 Pivot lever position, in mm

- ▶ Make sure that you consider the amount of torque that is generated by the drive when you design the weld between the bracket and the end product. The maximum torque is:
 - OKIMAT IPS: 435 Nm
 - OKIMAT IPSe: 325 Nm
 - OKIMAT 2 IPS: 435 Nm
 - OKIMAT EPS: 435 Nm
- ▶ We recommend the OKIN pivot lever (ID number 2.00.718.108.00)

6. Installation

6.1 Safety notices to observe during installation

Basic safety rules must be followed in order to ensure that the end product can be continually operated in a safe manner. These rules must be observed while using the end product and while installing the drive.

Avoiding fatigue fractures

Drives that are incorrectly installed can undergo fatigue fractures which then create a risk of injury.

- Install the drive in the end product so that it is properly aligned. This will help prevent shear stress.
- Do not position the drive at a slanted angle when installing it in the end product. A slanted angle between the intended direction of movement of the end product and the drive's direction will create shear stress and could lead to a fatigue fracture.

Avoiding a pinching hazard

When designing your end product, you should take the drive adjustment movement into account with passive safety mechanisms and with the appropriate safety notices in your operating instructions.

- Installation methods for ensuring passive safety: Install the OKIMAT drive so that none of the positions where shear and pinch hazards exist are accessible externally.

Make sure that your operating instructions inform the user of these safety points.

6.2 Installation procedure

6.2.1 An example installation

Before installing the drive, make sure that you are observing all of the safety notices found in the "Safety notices to observe during installation" section.

- 1 Move your product into a position where it is supporting no load.

 CAUTION
Danger of crushing injury! <ul style="list-style-type: none">• Be sure to carry out work on the drive in a position so that no loads are bearing on it. Only in this way can you be sure to avoid any risks of crushing or injury.• Disconnect the nine-volt battery if you are using the battery-operated reset function.

- 2 Pull the shutters firmly to the side (A). The slots (B) for the brackets (D) are now uncovered.

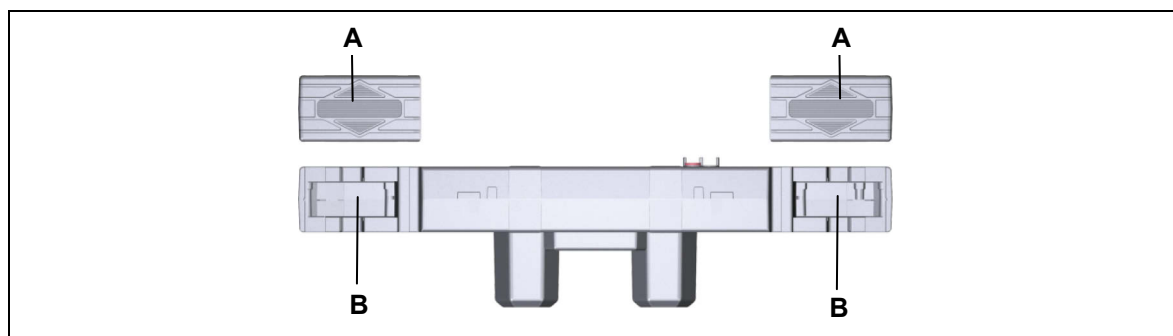

Figure 8 Installing the drive

A Shutters

B Fitting mounts

- 3 Align the OKIMAT in the proper position next to your end product. The slots for the back and leg sides must be properly aligned with the correct brackets on your end product (refer to the symbols on the OKIMAT as described in Figure 2).

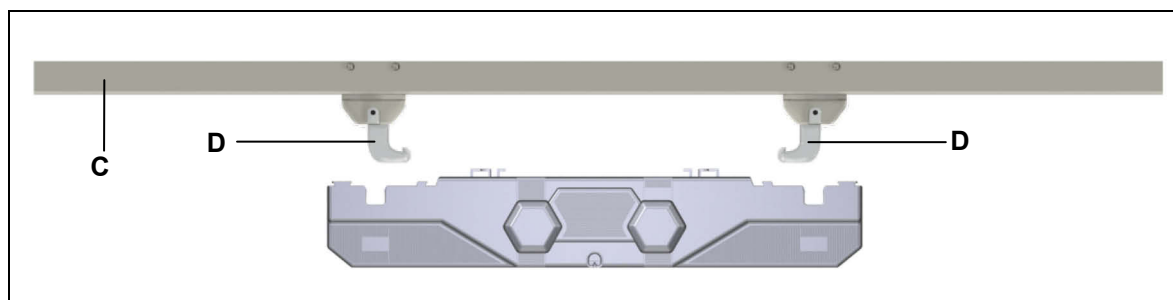

Figure 9 Installing the drive

C End product (bed)

D Brackets

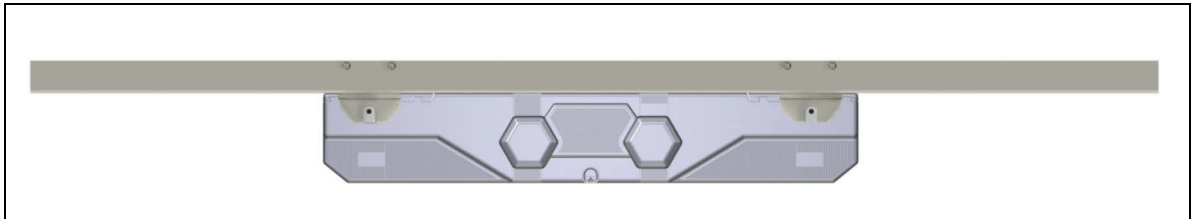

Figure 10 Installing the drive

- 4 Push the drive in so that the brackets (**D**) fit into the slots (**B**). Press in until the tubes snap into the brackets.
- 5 Close the shutters (**A**) on the drive by snapping them back in. The OKIMAT is now securely attached to the end product.
- 6 Disconnect all additional components (such as slave drives, handsets or PD12/PD13 power supply) from their sockets.
- 7 Now connect the drive to the power supply.

Please note, after the power supply has been connected:

- ▶ There is a delay after the supply voltage is applied before the device actually turns on. Wait at least two seconds before beginning the commissioning.

Looping the handset cable through the strain relief mechanism

Figure 11 Looping the cable through the strain relief mechanism

A Looped-in handset cable

B Cable fastened to strain relief

- 1 Connect the plug from the handset to the handset socket on the OKIMAT.
- 2 Loop the handset cable through the strain relief catch and pull back gently on the loop as illustrated in Figure 11.

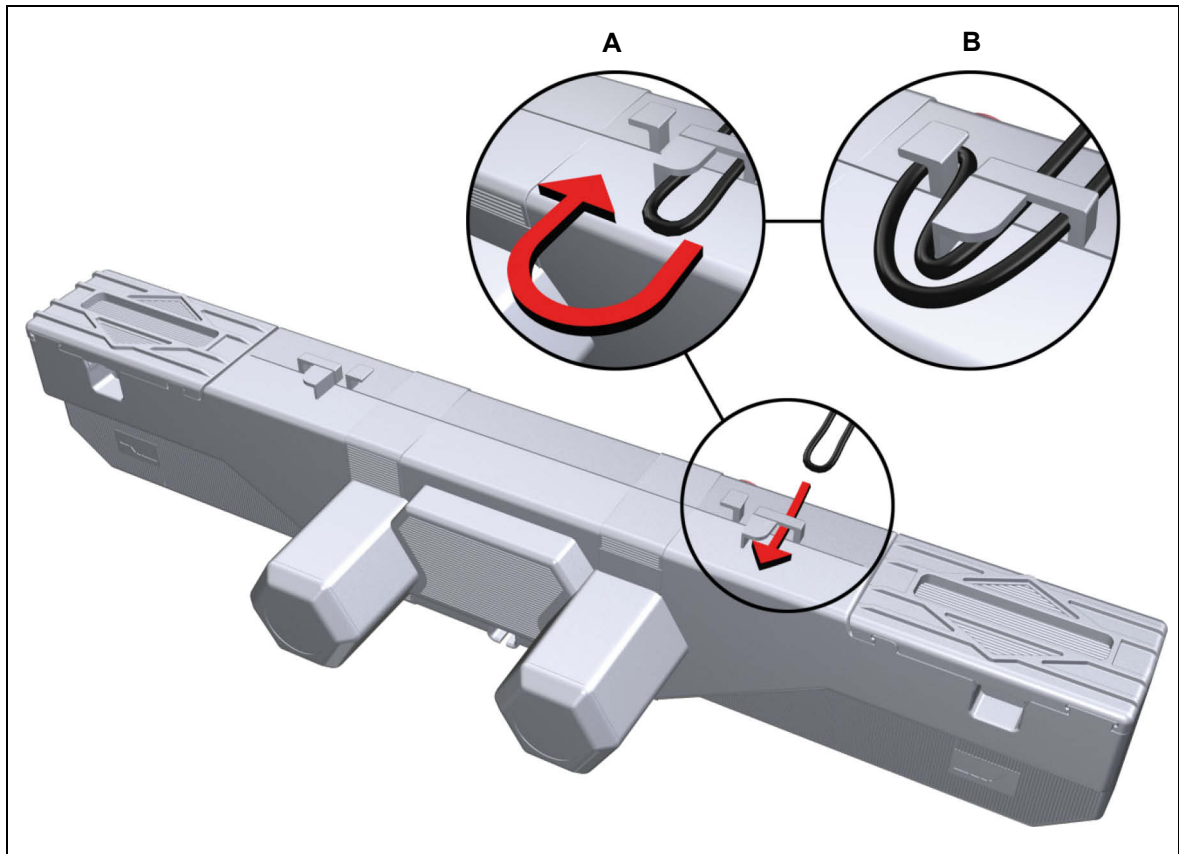
6.2.2 Electrical connection

⚠ CAUTION

Risk of accident

- Electrical components should be connected or disconnected only when the power supply cord is unplugged.
- Please note that residual electrical energy can even be present in the OKIMAT (IPS, IPS IPSE and 2) when it is unplugged.

- ▶ There is a delay after the supply voltage is applied before the device actually turns on. Wait at least two seconds before beginning the commissioning.

Option: Pluggable power cord (OKIMAT IPS)

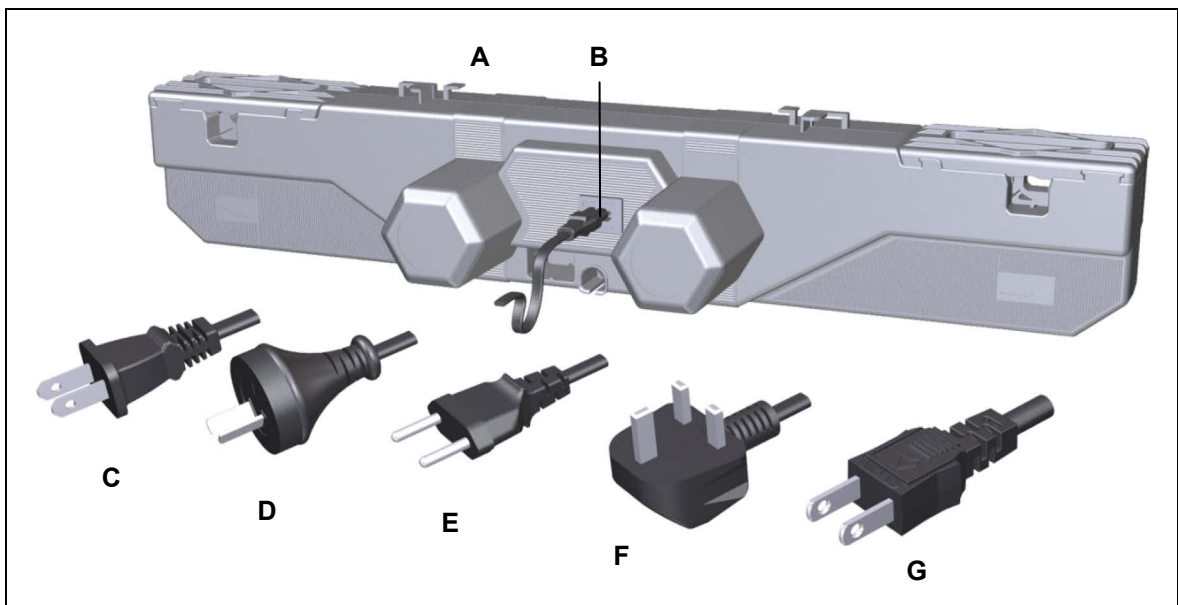

Figure 12 OKIMAT IPS (pluggable power cord)

- | | |
|---------------------------------|--------------------------------------|
| A OKIMAT IPS | B Power socket |
| C Power plug (USA) | D Power plug (Australia) |
| E Power plug (EURO flat) | F Power plug (United Kingdom) |
| G Power plug (Japan) | |

Option: attached power cord (OKIMAT IPSE, OKIMAT 2 IPS)

Only the following personnel are qualified to work on the attached power cord, mains cut-off, or power cord:

- someone who has completed training in electronic motor assembly,
 - someone with equivalent qualifications, or
 - someone who has successfully completed the appropriate DewertOkin training program.
- ▶ You should only work on the attached power cord when you are qualified to do so. Otherwise, a properly qualified person should be found for this task.

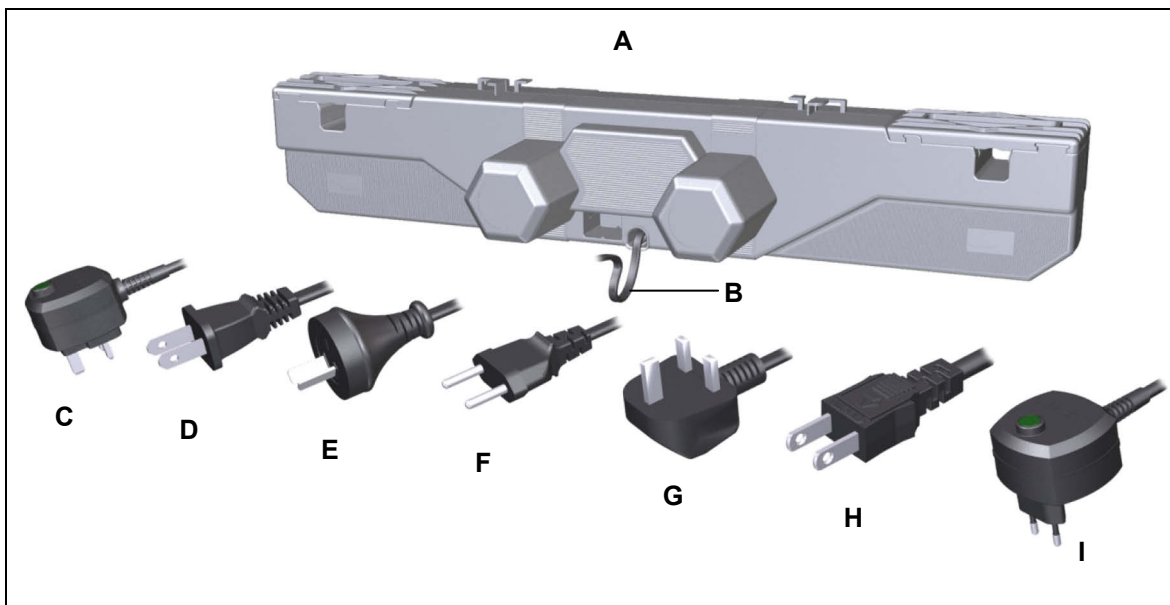

Figure 13 OKIMAT IPSe (with attached power cord) or OKIMAT 2 IPS (with mains cut-off)

A OKIMAT IPSe / OKIMAT 2 IPS	B Power cord
C Mains cut-off (United Kingdom)	D Power plug (USA)
E Power plug (Australia)	F Power plug (EURO flat)
G Power plug (United Kingdom)	H Power plug (Japan)
I Mains cut-off (EURO)	

Option: connecting the OKIMAT EPS to an external switched-mode power supply (SMPS)

The OKIMAT EPS should be connected to an external switched-mode power supply (SMPS: such as the PD12/PD13 power supply with the country-specific mains plug as described in the power supply's installation instructions) using a connecting cable, as shown in Figure 14.

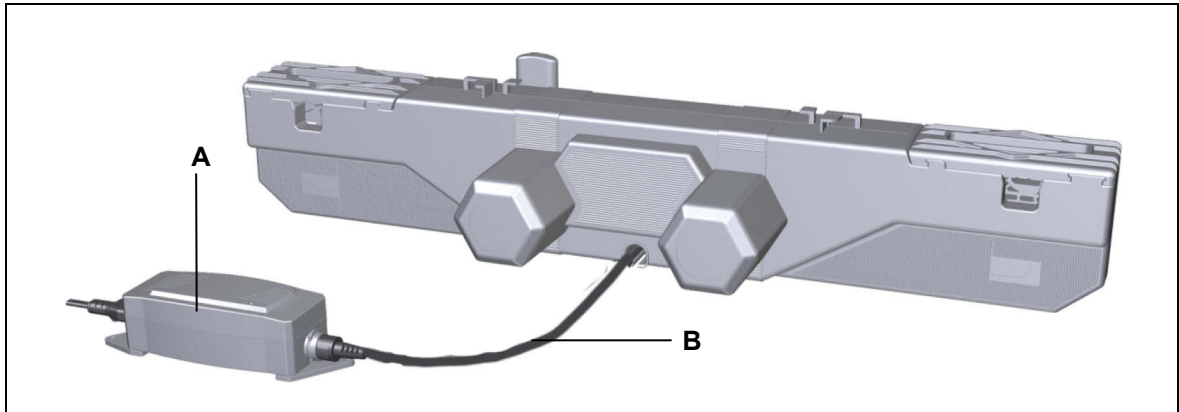

Figure 14 Connecting the OKIMAT EPS to an external switched-mode power supply (SMPS)
A Switched-mode power supply (e.g. PD12/PD13) **B** OKIMAT EPS connecting cable

Optional: battery-operated reset function

Connecting the nine-volt battery

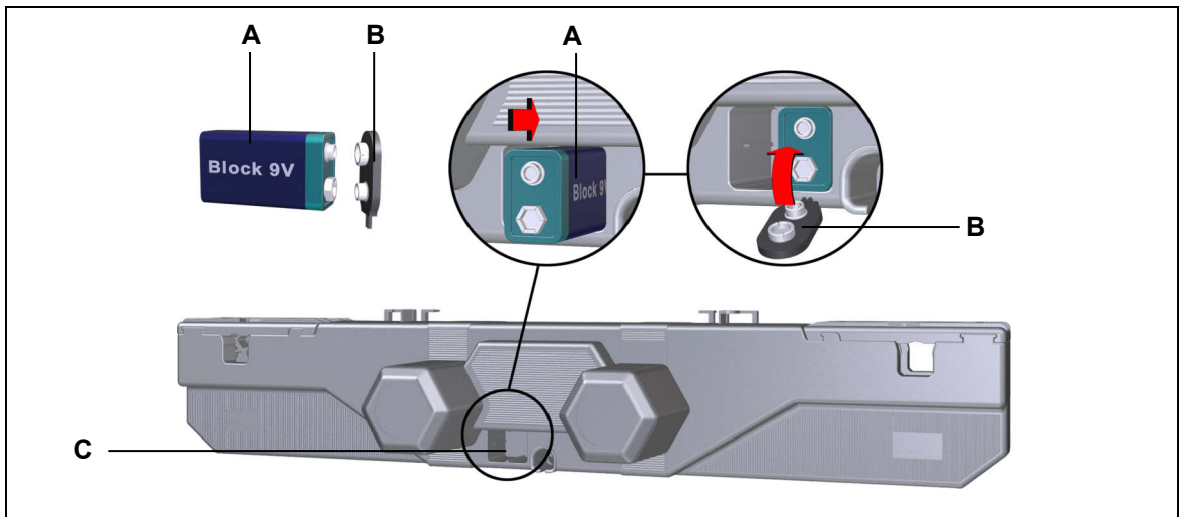

Figure 15 Connecting the nine-volt battery

A 9-V battery (type 6LR61)

B Battery clip

C Battery compartment

NOTICE

For the RF radio variants, the nine-volt battery may discharge whenever the mains voltage is not connected.

- ▶ DewertOkin recommends that you disconnect the nine-volt battery whenever the mains voltage is disconnected.

Routing the electrical cables

When routing the cables, be sure that:

- the cables cannot get jammed,
- no mechanical load (such as pulling, pushing or bending) will be put on the cables, and
- the cables cannot be damaged in any way.

Fasten all cables (especially the mains cable) to the end product using sufficient strain relief and kink prevention methods. Be sure that the design of the end product prevents the mains cable from coming into contact with the floor during transport.

6.2.3 Dismantling

<p>⚠ CAUTION</p>
<p>Risk of accident</p> <ul style="list-style-type: none"> • Work on electrical components should be conducted only when the mains power connection is unplugged. • Please note that residual electrical energy can even be present in the OKIMAT (IPS, IPS IPSE and 2) when it is unplugged. • Disconnect the nine-volt battery if you are using the battery-operated reset function.

► Certain details may change because of technical changes.

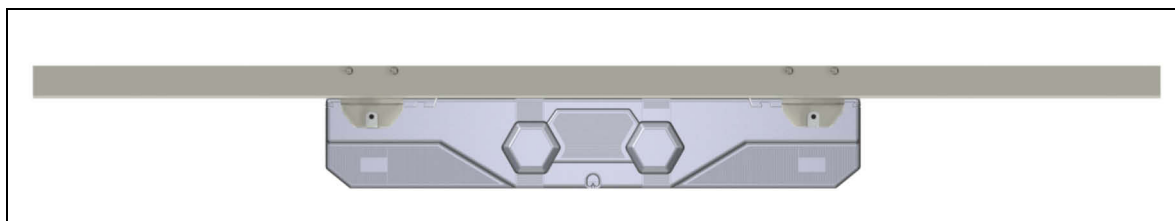

Figure 16 Removing the drive

1 Move your product into a position where it is supporting no load.

<p>⚠ CAUTION</p>
<p>Danger of crushing injury!</p> <p>Be sure to carry out work on the drive in a position so that no loads are bearing on it. Only in this way can you be sure to avoid any risks of crushing or injury.</p>

- 2 Disconnect the OKIMAT from the power supply!
 - 3 Disconnect all additional components such as slave drives or handset from their sockets.
- Be sure to support the drive's weight to prevent it from falling.
- 4 Pull strongly on the shutters (A) sideways until they are completely out.

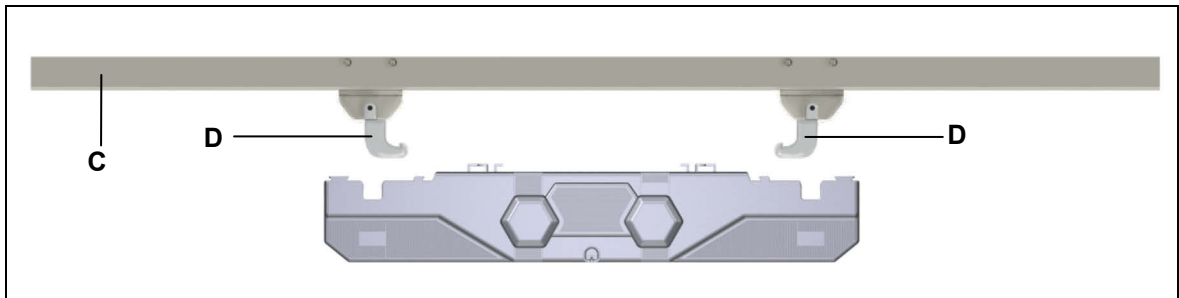

Figure 17 Removing the drive

C End product (bed)

D Brackets

- 5 Pull out the OKIMAT far enough so that the brackets (**D**) are out of the slots (**B**). The OKIMAT is now unattached and can be removed.

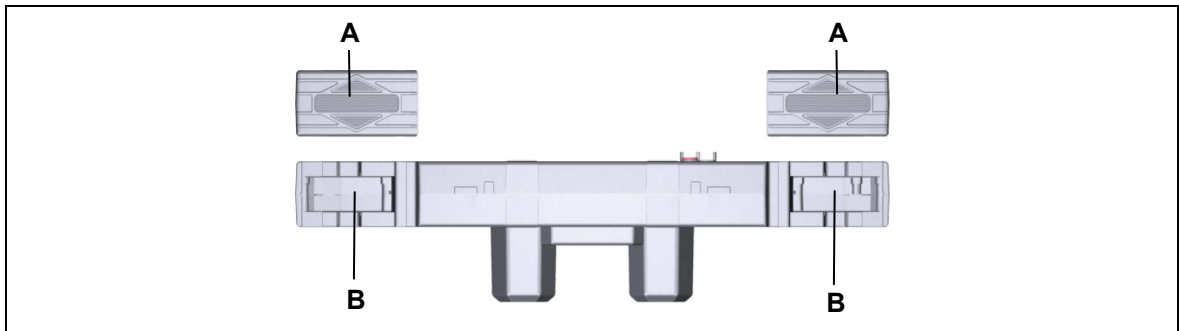

Figure 18 Removing the drive

A Shutters

B Fitting mounts

- 6 Push the shutters (**A**) back onto the OKIMAT 6 so that they are not lost during transportation.

7. Information about creating your Operating Manual

The factual information contained within may be used when you are creating the end-product manual. The installation instructions do not contain all information required for the safe operation of the end product. They only describe the installation and operation of the drive as a partially assembled piece of machinery.

- ▶ When creating the operating instructions, remember that the installation instructions are intended for qualified specialists and are not for typical users of the end product.

7.1 General information

- ▶ Only a DewertOkin device should be used to control the drive since they have already been verified to work together.

Delayed start-up

After plugging the power plug into the power outlet:

- ▶ There is a delay after the supply voltage is applied before the device actually turns on. Wait at least two seconds before beginning the commissioning.

Power-on time / intermittent operations

The OKIMAT drive has been designed for intermittent operations. Intermittent operation is an operational mode where the drive must pause after a specified maximum period of operation (power-on time). This protects the drive from overheating. Extreme overheating can cause a malfunction.

- ▶ The ratings plate on the drive specifies the maximum power-on time and the required pause intervals.

Shutting off the drive

To shut off the drive, first disconnect the system from the power supply and then disconnect the battery. The power supply must always be accessible during operations so that the system can be shut off.

7.2 Handset / hand-held remote control

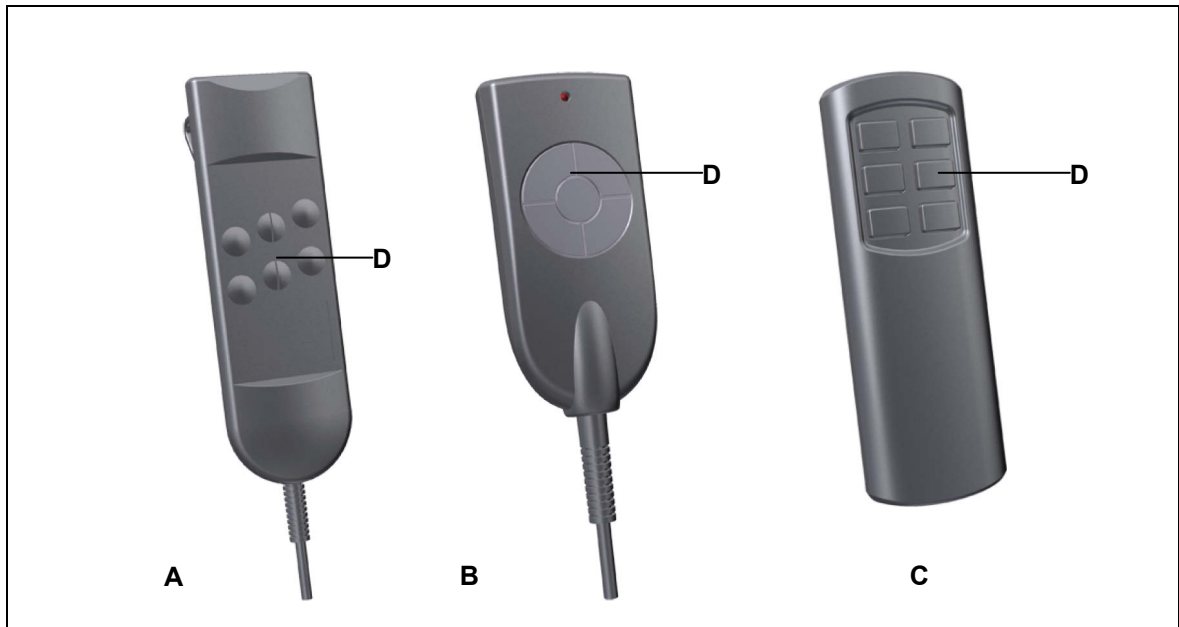

Figure 19 Examples of handset / hand-held remote control

- | | |
|--|----------------------------|
| A Baseline handset | B Smartline handset |
| C RF Eco hand-held remote control, for built-in radio receiver (RF) | D Adjustment keys |

- ▶ The adjustment motions are carried out by pressing on the corresponding symbol keys on the handset/hand-held remote control.

7.2.1 Programming the RF Eco hand-held remote

► Only for the model with integrated RF receiver.

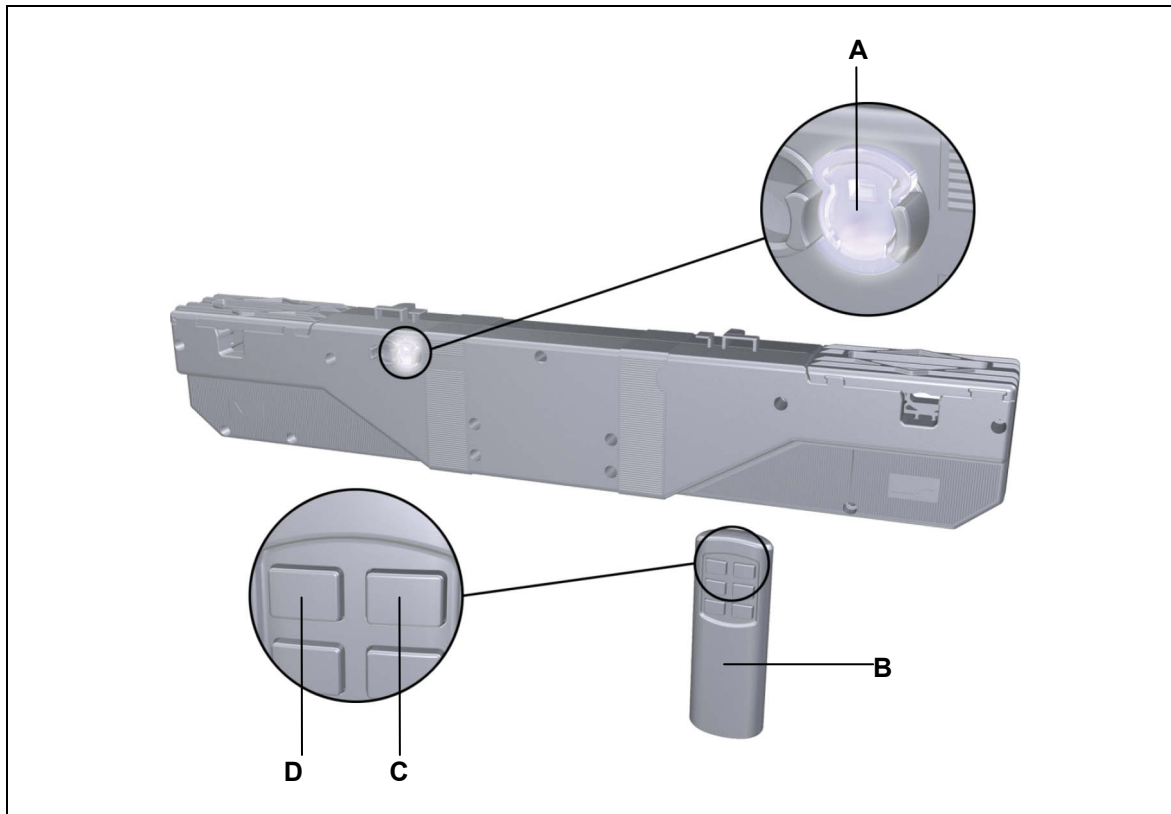

Figure 20 Programming the RF Eco hand-held remote

A Function key (at rear of the drive) **B** RF Eco hand-held remote

- 1 Press the function key on the drive (A in Figure 20) twice (a quick double click). The drive will now be in the teach-in (programming) mode for approximately 10 seconds. The LED on the function key lights up.
- 2 Press the (C) and (D) keys simultaneously on the RF Eco hand-held remote. Hold down both keys until the function key's LED starts to blink. The RF Eco remote is now programmed and ready to use.

7.2.2 Deactivating the RF Eco hand-held remote

You can interrupt communications between the hand-held remote and the drive; this is useful if you wish to decommission the remote or if the programming for the remote was unsuccessful. Take the following steps:

- 1 Press the function key on the drive (A in Figure 20) four times quickly.
- 2 Then press the function key (A) one more time. The RF Eco remote is now deactivated.

7.3 Notice for operating with optional configuration

7.3.1 Optional: battery-operated reset function

The battery-operated reset function allows the drive system to be operated during a power outage. A nine-volt battery is used to power the OKIMAT in the event of an outage. The battery is not connected by default since it has very limited capacity. It can only be used once to power the reset function. The used batteries should then be replaced and properly disposed of.

NOTICE

The battery-operated reset function is not a safety system and does not avert danger.

When working with radio units (RF), first disconnect the drive system from the power supply! Connect the nine-volt battery first when you would like to perform a battery-operated reset. The battery may only be used to power the reset function one time. Take out the battery and dispose of it properly after the reset function has been carried out.

- ▶ If the end product is under a heavy load which prevents the reset function from operating, the strain or load on the end product must first be removed before a reset can be carried out.

7.3.2 Additional operating controls

For more information on operating other controls, refer to the separate instructions for these controllers.

7.3.3 Optional: mains cut-off mechanism

For more information on operating other controls, refer to the separate instructions for these controllers.

The mains cut-off mechanism is responsible for isolating the drive automatically from the mains power supply when the drive is not moving. A switching component is used to isolate both poles of the power transformer from the mains power supply.

The mains cut-off mechanism allows power to the drive only after a button has been pressed on the handset to trigger drive motion.

- ▶ Do not use the integrated mains cut-off if you already use an in-house mains cut-off system.

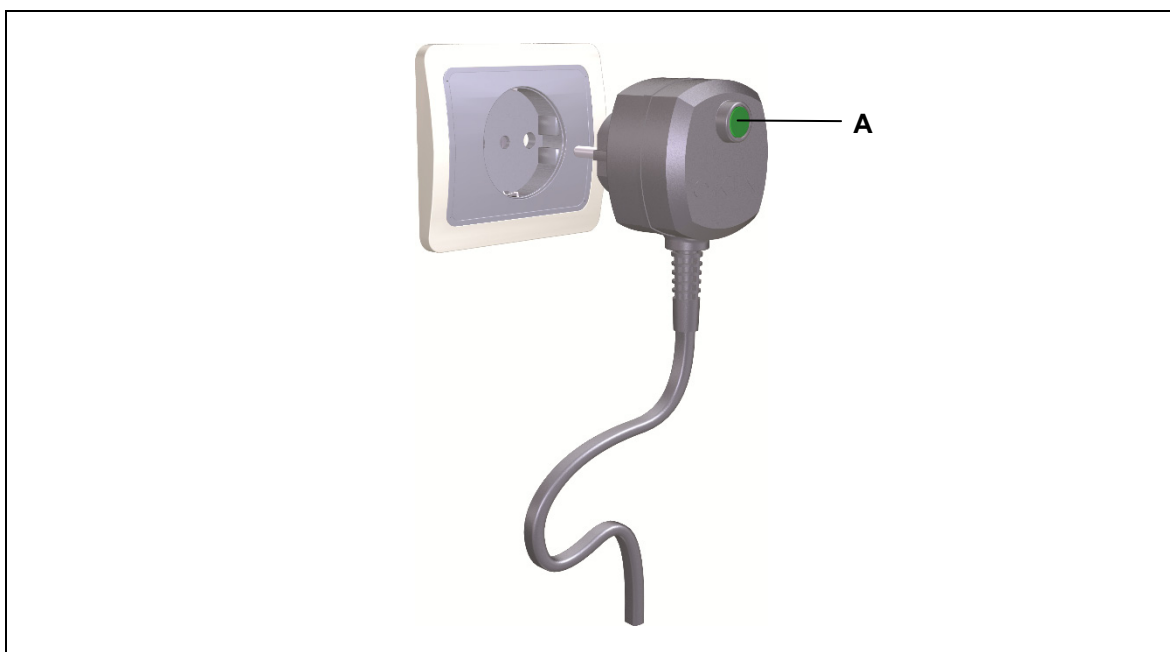

Figure 21 Mains plug with mains cut-off

A Key: Charge switching capacitor

<p>⚠ CAUTION</p> <p>The mains cut-off is not a "central command device" in the sense used by the DIN VDE regulations. You should first completely disconnect the voltage supply from the drive system before conducting any type of work on a DewertOkin product which features a mains cut-off. First pull out the power plug. This guarantees that the system is safely shut off in compliance with the German DIN VDE 0105 and DGUV/regulation 3.</p>

Note on operating the mains cut-off:

- To restore the connection to the mains, press a handset button to adjust the position of the drive.
- If this adjustment motion is not required, insert the mains cut-off plug into the socket. Then press the button on the mains cut-off plug. This charges up a switching capacitor and, when the button is pressed again on the handset, releases the mains connection for the adjustment movement.

8. Troubleshooting

This chapter describes troubleshooting methods for fixing problems. If you experience an error that is not listed in this table, please contact your supplier.

- ▶ Only qualified specialists who have received electrician training should carry out troubleshooting and repairs.

Problem	Possible cause	Solution
The handset or drive system is not functioning.	There is no mains supply voltage.	Connect the mains power.
	The hand switch or drive system is defective.	Please contact your supplier or sales agent.
	The switching capacitor in the mains cut-off is empty	Press the button on the mains cut-off plug after it has been plugged into the power supply.
The drive is suddenly no longer capable of movement.	The overheating protection or system protection has been triggered.	Remove the overload (change or remove the load). Allow the system to rest for 20 to 30 minutes with the mains power unplugged. If this does not resolve the problem, contact your supplier or distributor.
	The unit's fuse may have been triggered or may be broken.	Please contact your supplier or sales agent.
	There is no mains supply voltage.	Connect the mains power.
	A lead-in connection has been interrupted (mains power, hand switch or auxiliary drive).	Check the lead-in connections and re-seat the contacts if required.
The battery-operated reset is not functioning.	The battery is empty.	Check the battery and replace if necessary.
	Battery is not connected.	Connect the battery.

9. Maintenance

9.1 Maintenance

- ▶ The OKIMAT drive requires no maintenance.

9.2 Cleaning and care

- ▶ Clean the OKIMAT drive as needed using a dry cloth.

NOTICE

- Always disconnect the power supply before you start to clean the drive system!
- Disconnect the nine-volt battery if you are using the battery-operated reset function.
- Never clean the OKIMAT in an automated washing system or with a high-pressure cleaner. Do not allow fluids to penetrate the unit. Damage to the system could result.
- Do not use a cleanser that contains benzene, alcohol or similar solvents.
- Make sure that you do not damage the drive's connecting cable.

10. Disposal

10.1 Packaging material

The packaging material should be sorted into recyclable components and then disposed of in accordance with the appropriate national environmental regulations (in Germany according to the recycling law KrWG from 01.06.2012; internationally according to the EU Directive 2008/98/EC (Waste Framework Directive WFD as of 12.12.2008)).

10.2 Drive components

The OKIMAT drive consists of electronic components, cables and metal and plastic parts. You should observe all corresponding national and regional environmental regulations when disposing of the OKIMAT drive.

The disposal of the end product is regulated in Germany by Elektro-G, internationally by the EU Directive 2011/65/EC (RoHS), or by any applicable national laws and regulations. (The end product is not regulated by the EU Directive 2012/19/EC (WEEE).)



The OKIMAT drive should not be disposed of with normal household waste!

The disposal of the nine-volt batteries is regulated in the EU by Battery Directive 2006/66/EC, in Germany by the BattG battery law of 25.6.2009, and internationally by any applicable national laws and regulations.



The battery should not be disposed of with normal household waste!

Declaration of Incorporation/Installation

According to Appendix II of the EU Machinery Directive 2006/42/EC

The manufacturer:
DewertOkin GmbH
Weststraße 1
32278 Kirchlengern
Germany

declares that the incomplete machines described below

OKIMAT IPS; OKIMAT IPSe; OKIMAT 2 IPS; OKIMAT EPS

complies with the following basic requirements of the Machinery Directive (2006/42/EC):

Sections: 1.1.3; 1.3.3; 1.3.4; 1.3.7; 1.5.1; 1.5.2; 1.5.5; 1.5.6; 1.5.7; 1.5.8;
1.5.9; 1.5.10; 1.5.13; 1.6.3

You may only operate this incomplete machine after you have confirmed that the end product (into which this machine will be installed) complies with the Machinery Directive 2006/42/EC.

On request, the manufacturer is obliged to send the special documentation accompanying the partially completed machinery in electronic form to the appropriate national institution. The special technical documents corresponding to the machine have been created according to Appendix VII, part B.

The following person is responsible for the technical documentation: Hans-Joachim Heimsath,
Address cited above.
Tel.: 05223 979-0

Kirchlengern, Germany. The 08.April 2015



Dr.-Ing. Josef G. Groß
Managing Director

EU Declaration of Conformity

In compliance with Appendix IV of the EU EMC Directive 2004/108/EC

In compliance with Appendix III of the EU Low Voltage Directive 2006/95/EC

In compliance with Appendix VI of the EU RoHS Directive 2011/65/EU

The manufacturer:

DewertOkin GmbH

Weststraße 1

32278 Kirchlengern

Germany

declares that the following products

OKIMAT IPS; OKIMAT IPSe; OKIMAT 2 IPS; OKIMAT EPS

meets the requirements of the following EU directives:

Electromagnetic Compatibility Directive 2004/108/EC

Low Voltage Directive 2006/95/EC

RoHS Directive 2011/65/EU of the European Parliament and of the Council of 8 June 2011 on the restriction of the use of certain hazardous substances in electrical and electronic equipment

Applied standards:

- EN 60335-1:2012
- EN 55014-1/A2:2011
- EN 55014-2/A2:2011
- EN 61000-3-2/A2:2009
- EN 61000-3-3:2013
- EN 62233:2008

This declaration of conformity is no longer valid if constructional changes are made which significantly change this drive (i.e., which influence the technical specifications found in the instructions or the intended use)!

Kirchlengern, Germany. The 08.April 2015



Dr.-Ing. Josef G. Groß
Managing Director

DewertOkin GmbH
Weststrasse 1
Kirchlengern 32278, Germany
Tel: +49(0)5223/979-0
Fax.: +49 0 522375182
<http://www.dewertokin.de>
Info@dewertokin.de

ID No.: 78434