



SUPERVISOR

Installation Instructions

**(Translation of the original
installation instructions)**

SUPERVISOR

Contents

	page
General Information.....	2
Designated Use.....	3
Prerequisites.....	3
Getting to Know the System.....	5
Fitting.....	7
Operation.....	8
Maintenance and Repairs.....	11
Type Label.....	12
Connecting Diagram.....	13
Troubleshooting.....	14
Cleaning and Care.....	15
EU Declaration of Conformity.....	16

General Information

These instructions are intended for the manufacturer of the end product and are not designed for passing on to the operator of the end product. However, with regard to the specialist information contained herein, they can well serve as a basis for drawing up the end product manual.

It is essential to note the information contained in these instructions! In doing so, you can prevent mistakes being made in installing or connecting the system which could result in

- **injury and accidents as well as**
- **damage** to the drive system or the end product.

DEWERT **accepts no liability** for damage caused as a result of...

- non-observance of these instructions,
- alterations to the product not approved by DewertOkin or...
- the use of spare parts not manufactured or approved by DewertOkin- it is possible that these do not ensure adequate safety!

Due to the policy of ongoing product improvement, DewertOkin reserves the right to carry out technical changes at any time without prior notification!

1. Designated Use

The **SUPERVISOR** operating element is **designed** for actuating DewertOkin drive systems and for locking (blocking) or releasing adjustment functions, e.g. in beds.

- for the disabled,
- for the hospital sector.

The **SUPERVISOR** operating element is **not intended for use...**

- in an environment where **inflammable** or **explosive** gases or vapours (e.g. anaesthetics) are likely to occur,
- in a damp environment, i.e. outdoors,
- In applications intended for cleaning in wash tunnels, (optional wash tunnel proof possible). Contact your supplier.
- in applications used by small children or fragile persons.
- in the immediate vicinity of young children.

2. Prerequisites

The installation steps described in these instructions must be performed by a **fully trained electrical engineer**.

- This being the case, you should never carry out this work **yourself** unless you are a **qualified electrical engineer** or
- you **should entrust** this work to suitably **qualified persons** only.

Conformity according to EC Directives

The **SUPERVISOR** operating element is supplied ex factory as a **machine not ready for use** in accordance with the EC Machinery Directive. In other words, you may not put the drive control system into operation until you have met the **safety objectives** of the Machinery Directive and issued a corresponding **Declaration of Conformity!**

The drive system meets the safety objectives of the EC Directives concerning "**Low Voltage**" and "**Electromagnetic Compatibility (EMC)**".

The **SUPERVISOR** operating element is **not a medical product** - for installing into same, manufacture in **conformity** with the EC Directive for "Medical Products" or other regulations is the responsibility of the **manufacturer of the end product**. For this purpose, in the case of the CARE L/CARE/HOSP drive systems, DewertOkin has additionally applied, fully or partially, a number of standards from the medical products sector, in order to **facilitate** use in medical products, e.g.

EN60601-1	Safety of Electromedical Equipment
EN60601-1-2	Electromagnetic Compatibility of Electromedical Equipment
EN60601-2-38	Safety of Hospital Beds
EN1970	Adjustable Beds for the Disabled

SUPERVISOR

Caution! **For your own safety!**

When designing the **layout of the bed**, avoid areas in which inadvertent movements could prove hazardous.

Shutdown in an emergency is achieved by **pulling out the mains plug from the drive system!** The mains plug must therefore be accessible at all times when the system is in operation to ensure it can be quickly pulled out of the wall socket in an emergency. If despite **pulling out the mains plug**, a movement persists due to the optional battery backup system, this can be stopped by locking all the functions on the **SUPERVISOR**. If necessary, **pull out the battery pack's plug**.

Avoid subjecting the mains cable and connecting cable to mechanical loads. Regular visual checks of the cables should be carried out at short-term intervals and in particular each time it has been subjected to a mechanical load.

If the mains cable of the drive system gets damaged, it must be replaced in order to prevent hazards. **Work to and replacement of the mains cable may only be carried out by specialist personnel holding the qualifications described on page 3 or by persons who have taken part and successfully completed the corresponding training programmes offered by DewertOkin.**

In the Operating Instructions to be drawn up by yourselves, it is essential that you draw the operator's attention to the points mentioned here.

3. Getting to Know the System

The **SUPERVISOR** operating element is intended for the German market and complies with the Law applicable in Germany in implementation of relevant EC Directives.

To put the **SUPERVISOR** operating element into operation, **further components, e.g. control unit, double drive in versions CARE L/CARE/HOSP ...** are required.

The **SUPERVISOR** comprises a closed plastic casing and a spiral cable. The **SUPERVISOR** is easy and convenient to operate thanks to a membrane keypad with perceptible switching point, covered with an easy-care robust polyester film with large symbols and raised push-buttons. All the control elements are located underneath a transparent hinged lid to protect them against soiling and inadvertent actuation.

The **SUPERVISOR** allows the medical staff to selectively lock or release individual adjustment options of the application. The lock is effective for all connected actuators. It is only from here that also all the other more extensive adjustments, such as "Trendelenburg, the tilt facility and the neutral position" can be operated.

Connectable components

Operating Element	Main Drive	Control Unit
SUPERVISOR	DUOMAT 7 ¹⁾ DUOMED	MCL ¹⁾ SG 300 ¹⁾ SGAG 300 ¹⁾ MBXL ²⁾
SUPERVISOR FURNIBUS		MCL ^{1,3)} SG 300 ^{1,3)}

1) Versions CARE/CARE L and HOSP

2) Versions CARE/CARE L

3) Versions FurniBus

a) Relevant dimensions (mm)

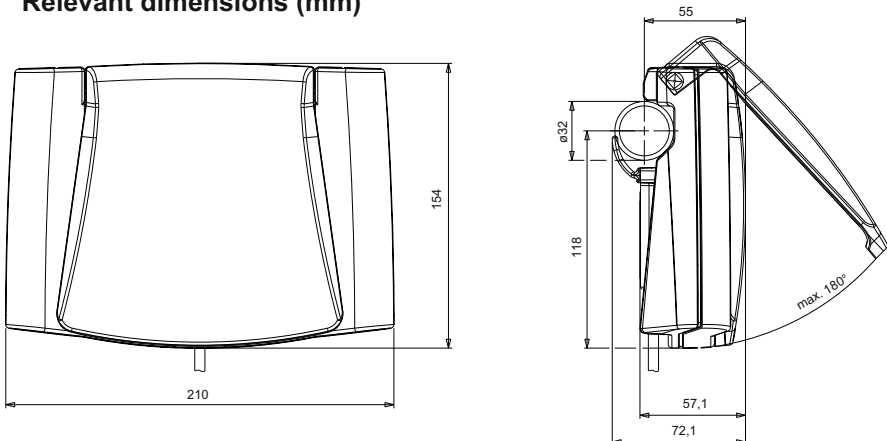

SUPERVISOR

b) Technical data

Input voltage.....:	24 V DC SELV max. 40 V DC SELV
Approved current capacity, contact load rotary switch.....:	max. 150 mA
Approved current capacity, Contact load adjustment key.....:	max. 50 mA
Protection classification.....:	III
Lockable drives.....:	1 - 5
Equipment versions.....:	- Trendelenburg, - Antitrendelenburg, - A client/patient-specific bed position can be individually memorized - Can be actuated to travel to the shock position on the press of a button - charge control indicator, - Error/fault control indicator
Protection category.....:	IPX6 (optional wash tunnel proof ¹⁾)
Colours.....:	grey

Dimensions and weights

Length x width x height.....:	approx. 210 x 154 x72,1 mm (with closed lid)
Weight.....:	approx. 0,7 kg

Ambient conditions for operation, storage and transport

Transport / storage temperature.....:	from -20 °C to +50 °C from -4 °F to +122 °F
Operating temperature.....:	from +10 °C to +40 °C from +50 °F to +104 °F
Relative humidity.....:	from 30% to 75%
Air pressure.....:	from 800 hPa to 1060 hPa
Height.....:	< 2000 m

¹⁾ The operating element is suitable for cleaning in a decontamination chamber provided the following conditions are met:

- A cleaning and disinfecting cycle in wash tunnels must not exceed 6 minutes maximum.
- The agent used for the washing process (rinsing water) must have a pH of between 6 and 8. Its degree of hardness must not exceed 7° dH. The total salt content must not exceed 100 mg/litre.
- The sprays must be structured so, that the water cannot form pointed jets on contact with the furniture
- The pressure of the water sprays must not exceed 6.5 bar.
- During the washing process the temperature of the furniture must not exceed 65°C to 70°C. A temperature too far below the recommended level is also to be avoided as this produces poor drying results.
- The cleaning and disinfecting solutions used must not contain any substances which cause changes to the surface structure or the adhesive properties of the plastic materials.
Recommendation: neodic Dekonta; neodic BP or identical agents; neodic TN
- Cold water rinsing is not permitted
- After drying, a leakage current test must be carried out.

4. Fitting

The supply package includes a **SUPERVISOR** - and depending on the order, a **control unit CARE L/CARE/HOSP**, a **double drive CARE L/CARE/HOSP**, a **handset** and **slave drives**. The components are prewired ready to plug in.

a) Installation (examples)

Caution!

Only ever connect or disconnect electrical components when they are **voltage-free**.

Example: Push the **SUPERVISOR (1)** onto the **tubular frame (2) ø32 mm** on the bed. The **SUPERVISOR** is clamped between **casing (3)** and **clamp (4)**. Make sure that the **connection cable (5)** is not or cannot get trapped in any way. Afterwards connect the connection cable to the correct socket of the control unit/drive, see wiring diagram on page 12.

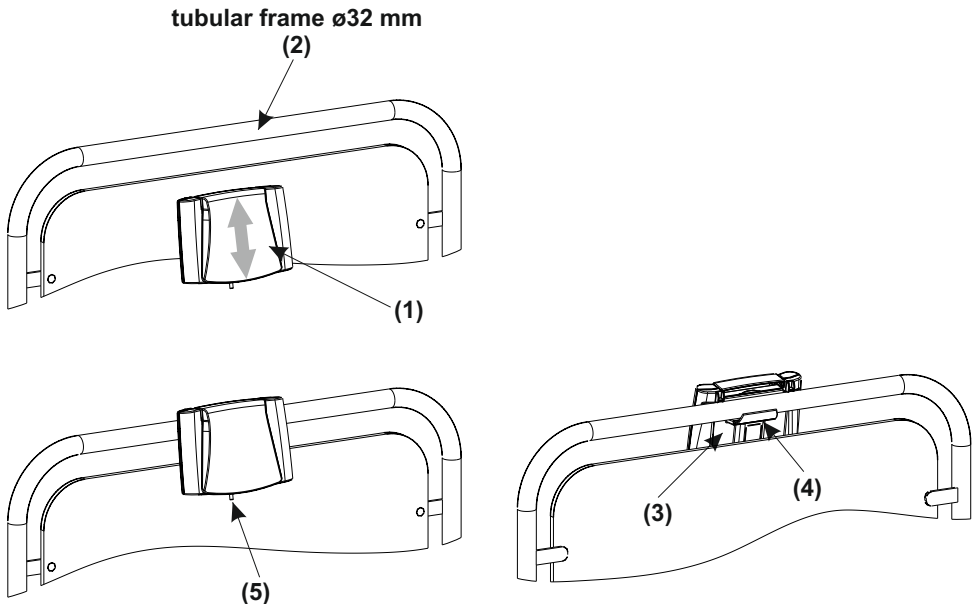

SUPERVISOR

b) Electrical connection

In the **Operating Instructions** to be issued by you, point out to the operator that if cables are **driven over**, they could sustain damage. **Mechanical loads should also be avoided.**

When routing the cables make sure that they

- cannot get entangled or trapped,
- are not subjected to mechanical loads (i e. do not pull, apply pressure or bend),
- cannot get damaged in any other way.

Make sure that the cables, in particular the **mains cable**, are fastened to the application with adequate **strain relief** and **kink protection** and that suitable constructional measures prevent the **mains cable from trailing on the floor** when the application is being **moved**.

C) Dismantling

Disconnect the plug-in connectors from the respective connecting sockets.

Dismantling takes place in reverse sequence.

5. Operation

For drawing up the Operating Instructions for the End Product, you can use the specialist information described herein. Please bear in mind that these instructions are intended for you as a specialist and not for the potentially non-professional operator of the end product.

Attention!

- **The SUPERVISOR is not intended to be used by small children or the unsupervised infirm.**
- **The SUPERVISOR is not a toy for children to play with.**

a) Prerequisites

The functions of **adjustment keys are only available** provided **these are not blocked** on the **SUPERVISOR**. In certain circumstances it may be advisable to block functions in order to prevent specific movements from being carried out.

b) SUPERVISOR function (example)

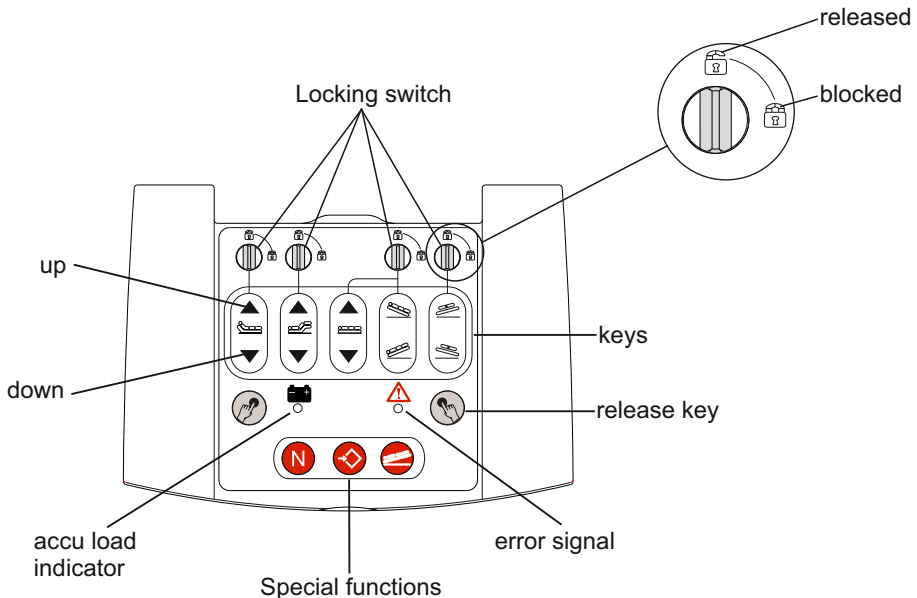

The **SUPERVISOR** control system affords the hospital/nursing staff complete control over the drive's control system.

To lock the adjustment functions, proceed as follows:

- Turn the **locking switch** to the "**blocked**" position.
- **Check** that the function is blocked by pressing the corresponding adjustment key on the handset. The drive should be **immobilized**.
- If movement is carried out, the drive system must be replaced immediately.

When using control elements which are not first-fault safe, first-fault safety can only be guaranteed by locking the adjustment functions.

Caution!

The lock switches interrupt the control voltages of the respective motor relay. In bed systems in which the functions are implemented via an identical motor group (e.g. height adjustment, Trendelenburg), all the functions assigned to that particular motor group are basically locked as a result.

SUPERVISOR

c) Symbols on the SUPERVISOR (example)



Lock switch in **"release"** position, all the adjustment buttons assigned to the lock switch are now operational.



Lock switch in **"locked"** position, all the adjustment buttons assigned to the lock switch are now locked.



"Release button" option: The **SUPERVISOR** allows the adjustment functions to be **released or locked** and can be designed as a dual-handed actuator to ensure that inadvertent adjustment cannot take place. It is then only possible to perform an adjustment if one of the two release buttons, which is labelled by the adjacent symbol, is pressed at the same time.



Back rest adjustment: By pressing the button symbol the tilt angle of the back rest is altered.



Thigh rest adjustment: By pressing the button symbol the tilt angle of the thigh rest is altered.



Height adjustment: By pressing the button symbol the height of the bed is altered. Where height adjustment takes place at the highest or lowest position, the bed, if tilted, automatically travels to the horizontal position.



Tilting the mattress base: By pressing the button symbol the angle of the mattress base can be tilted to achieve the head-down or foot-down position. If the control unit is correspondingly equipped, the full tilt range can be accessed from whatever height the mattress base is set at. In the process the height of the mattress base is therefore automatically adjusted to avoid collisions.



Lateral tilting of the mattress base: By pressing the button symbol the mattress base can be laterally tilted.



Neutral position: By pressing the button symbol the bed can be brought to the neutral position. This is preset at the factory, back rest, thigh rest and mattress base travel to the horizontal starting position.



Saving positions: By pressing the button symbol, a new home position can be set.



Shock position: By pressing the button symbol, the bed can be brought to the shock position. In the process, the back rest and thigh rest travel simultaneously to the horizontal home position and the mattress base is tilted to the head-down position.

Attention: This function may only be performed by a medical specialist. Actuation demands utmost attention on the part of the operator.



"Error/fault indicator" option: The control lamp (LED) flashes or lights up constantly when a malfunction has occurred.



"Backup battery indicator" option: This features a dual-coloured control lamp (LED) which, when the unit is being run off the mains, indicates the charge status and that the integral backup battery system is working correctly.

- The control lamp (LED) flashes green/yellow when the battery is being charged.
- The control lamp (LED) flashes yellow constantly when the battery is fully charged.
- The control lamp (LED) glows green constantly if, on switching the mains on, the battery was already fully charged or is not plugged in.

The layout of the **SUPERVISOR** and the function range are often tailored to the customer's needs or the application requirements. As a result, the functions and symbols could well differ from those depicted in these instructions. For a detailed description of your **SUPERVISOR**, please contact your customer support.

d) Maintenance and Repairs

At regular intervals carry out the inspections. The recommended inspection period is: **6 months**

In addition to the above, the following checks should be carried out at shorter intervals:

- **Regular visual checks** for damage of all kinds
Check the housing for cracks and fractures and the mains connection lead, handset leads and drive leads for signs of pinching and shearing-off. Also check the strain relief with kink protection, in particular after each case of mechanical loading. Any **damaged connection leads** of equipment must be replaced by **the manufacturer** or **persons qualified** to do so (see page 3) in order to exclude hazards.

SUPERVISOR

6. Type label

Each component carries a type label giving the exact designation, item number and technical specifications (for explanation see following figure as an example).

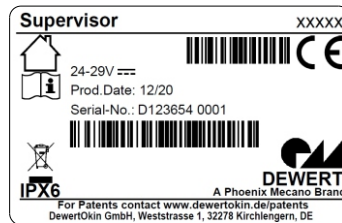

Supervisor

Xxxxx

24-29V

Prod.Date

Serial-No.

IPX6



Article type designation

Article number

Input voltage

Week / Year

Serial number

Protection category

Use in dry rooms only!

Follow all special disposal instructions!

Mark of CE conformity

8. Connecting Diagram with SUPERVISOR

(Example: SGAG 300 with additional equipment)

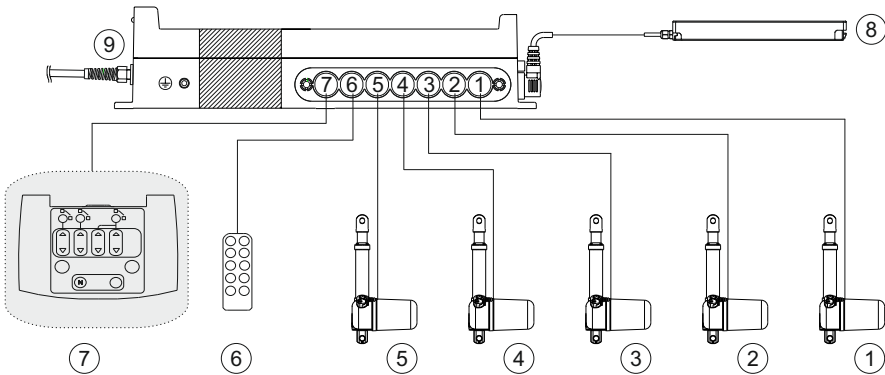

Only connect the components as shown!

This can otherwise result in damage to the drive control unit!

Pos.	Part designation	Description
1 - 5	DewertOkin Slave Drive	e. g. MEGAMAT, MEGAMAT 2 ...
6	DewertOkin Handset	Version depends on application range (e.g.: IPROXX ^{®1)})
7	DewertOkin Locking Device	SUPERVISOR
8	DewertOkin battery backup unit	e. g. AG 300, AG 7
9	DewertOkin Control Unit	e. g. SG 300 serial, MCL

1) without integral Locking Device

SUPERVISOR

7. Troubleshooting

The following table has been developed to help you detect and eliminate common faults and errors. If you come across a fault/error that is not listed here, please contact your supplier. All of these faults/errors may only be inspected and rectified by specialists holding the qualifications as described on page 3.

Problem	Possible Cause	Remedy
SUPERVISOR or drive system without function	<ul style="list-style-type: none">- SUPERVISOR or drive system defective- No supply voltage	<ul style="list-style-type: none">- Contact your supplier/ dealer- Check the feeder cable, if necessary restoring contact
No movements/ adjustments can be carried out	<ul style="list-style-type: none">- SUPERVISOR is blocked- Feeder cable (mains and/or Slave Drives/Locking Device) interrupted	<ul style="list-style-type: none">- Check switch position on the SUPERVISOR and, if necessary, release- Check the feeder cable, if necessary restoring contact
Acoustic signal (CARE/HOSP)	<ul style="list-style-type: none">- SUPERVISOR is blocked	<ul style="list-style-type: none">- Check switch position on the SUPERVISOR and, if necessary, release
Error LED glows constantly or flashes without a button having been pressed	<ul style="list-style-type: none">- SUPERVISOR or drive system defective	<ul style="list-style-type: none">- Contact your supplier/ dealer
Battery charge LED flashing	<ul style="list-style-type: none">- Battery is being charged	<ul style="list-style-type: none">- No error/fault detected

9. Cleaning

The cleaning of the **SUPERVISOR** has been designed to facilitate cleaning for the user, and this has been made even easier thanks to the large number of flat surfaces. The **SUPERVISOR** should be cleaned with a proprietary cleaning agent suitable for **ABS** using a damp cloth. Always note the instructions provided by the manufacturer of the respective cleaning agent used.

Before cleaning, always pull out the mains plug from drive system!

Only clean the **SUPERVISOR** unit in a wash tunnel if they are designated as wash tunnel proof. **Never** use a **high-pressure cleaner** on the **SUPERVISOR** or **spray fluids** directly onto them using jets. You risk damaging the equipment!

When **cleaning** take care not to damage the drive system **mains cable!**

Do not use **any solvents** such as **benzene, alcohol** or similar substances.

10. Disposal

The **SUPERVISOR** consists of electronic components, cables and metal and plastic parts. You should observe all corresponding national and regional environmental regulations when disposing of the **SUPERVISOR**.

The disposal of the product is regulated in Germany by Elektro-G, internationally by the EU Directive 2012/19/EC (WEEE), or by any applicable national laws and regulations



The **SUPERVISOR** may not be disposed of with the normal household waste!

SUPERVISOR

EU Declaration of Conformity

In compliance with Appendix IV of the EMC-Directive 2014/30/EU

In compliance with Appendix IV of the LVD-Directive 2014/35/EU

In compliance with Appendix VI of the EU RoHS Directive 2011/65/EU (incl. Commission delegated Directive (EU) 2015/863)

The manufacturer:

**DewertOkin GmbH
Weststraße 1
32278 Kirchlengern
Deutschland - Germany**

declares that the following product

SUPERVISOR with DewertOkin drive system

meets the requirements of the following EU directives:

Electromagnetic Compatibility Directive 2014/30/EU

Low Voltage Directive 2014/35/EU

COMMISSION DELEGATED DIRECTIVE (EU) 2015/863 of 31 March 2015 amending Annex II to Directive 2011/65/EU of the European Parliament and of the Council as regards the list of restricted substances.

Applied standards:

**EN 60335-1:2012/A11:2014
EN 55014-1:2006/A1:2009/A2:2011
EN 55014-2:1997/A1:2001/A2:2008
EN 61000-3-2:2014
EN 61000-3-3:2013
EN 62233:2008**

This declaration of conformity is no longer valid if constructional changes are made which significantly change the drive system (i.e., which influence the technical specifications found in the instructions or the intended use)!

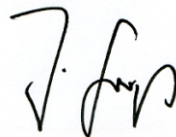

Kirchlengern, Germany 19 March 2020

Dr.-Ing. Josef G. Groß
Managing Director

Notes

SUPERVISOR

Notes

Notes

SUPERVISOR



DewertOkin GmbH
Weststraße 1
32278 Kirchlengern, Germany
Phone: +49 (0)5223/979-0
Fax: +49 (0)5223/75182
<http://www.dewertokin.de>
Info@dewertokin.de