

OFFICE SYSTEMS

Better Components, Better Furniture

NEW

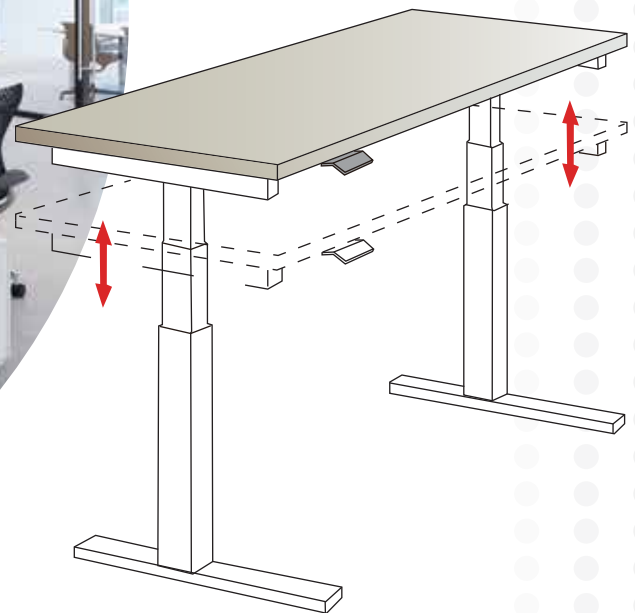

One-stop Solution for Smart Office

Our success hangs on that of our customers.

Close cooperation, constant communication and intensive exchanges of well targeted ideas are our main precepts. Focusing on customer needs, we provide professional product services and one-stop solutions for smart furniture.



SERVICE AROUND THE WORLD

Our professional international service team provides support to all our customers worldwide.

Approved by authoritative certification institutions



Desk Systems

OKIN's Desk Systems are the perfect solution for those looking for flexibility and optimal support. Simple to assemble, our frames are adjustable, easily adapting to a wide range of sizes, while providing a strong stable structure.

OKIN's Desk Systems can be customized according the customer needs on request.

Colors



- Noise <48dB
- Anti-Collision



Dual Column System

DS2 Single Motor

Load Capacity	800N
Max Speed	25mm/s
Min Height	695mm
Stroke	480mm
Max Height	1175mm
Frame Width	1100-1500mm
Outer Profile	80*50mm
Number of Profile	2Stage



DS2 Dual Motor

Load Capacity	800N
Max Speed	25mm/s
Min Height	690mm
Stroke	500mm
Max Height	1190mm
Frame Width	1100-1500mm
Number of Profile	2Stage



DIN fb 147 Pass for DACH

DS2 Dual Motor

Load Capacity	1200N
Max Speed	35mm/s
Min Height	600mm
Stroke	650mm
Max Height	1250mm
Frame Width	1100-1800mm
Number of Profile	3Stage



DIN fb 147 Pass for DACH

DS2 Rapid Mount

Load Capacity	1200N
Max Speed	35mm/s
Min Height	600mm
Stroke	650mm
Max Height	1250mm
Frame Width	1100-1800mm



Triple Column System

DS3 / 90°

Load Capacity	1500N
Max Speed	35mm/s
Min Height	600mm
Stroke	650mm
Max Height	1250mm
Main Frame Width	1100-1800mm
Auxiliary Frame Width	1280-1800mm
Number of Profile	3Stage



DS3 / 90° 120° 180°

Load Capacity	1500N
Max Speed	35mm/s
Min Height	600mm
Stroke	650mm
Max Height	1250mm
Frame Width	1100-1800mm
Number of Profile	3Stage



DS3 / 180°

Load Capacity	1500N
Max Speed	35mm/s
Min Height	600mm
Stroke	650mm
Max Height	1250mm
Frame Width	2200-3600mm
Number of Profile	3Stage



Triple Pack System

DS9 / 120°

Load Capacity	1500N
Max Speed	35mm/s
Min Height	600mm
Stroke	650mm
Max Height	1250mm
Number of Profile	3Stage

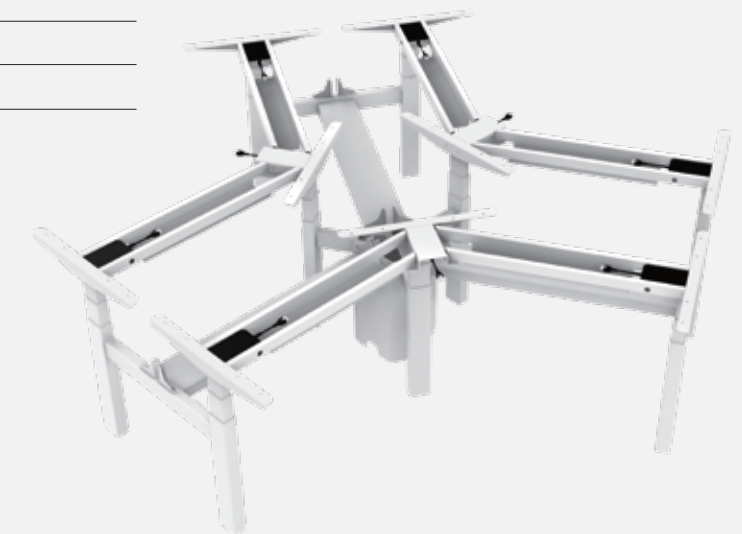



Face-to-Face Bench System

DS4

Load Capacity	1200N
Max Speed	35mm/s
Min Height	600mm
Stroke	650mm
Max Height	1250mm
Frame Width	1100-1800mm
Number of Profile	3Stage



Dual Bench System

DS8

Load Capacity	1200N per side
Max Speed	35mm/s
Min Height	600mm
Stroke	650mm
Max Height	1250mm
Frame Width	1406-3026mm
Number of Profile	3Stage

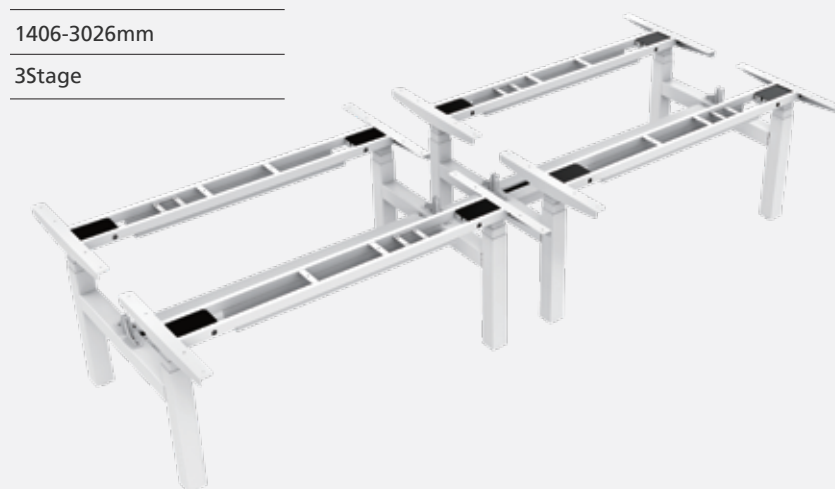

Conference Desk System

DS6

Load Capacity	1200N
Max Speed	35mm/s
Min Height	600mm
Stroke	650mm
Max Height	1250mm
Frame Width	2800-4000mm
Number of Profile	3Stage

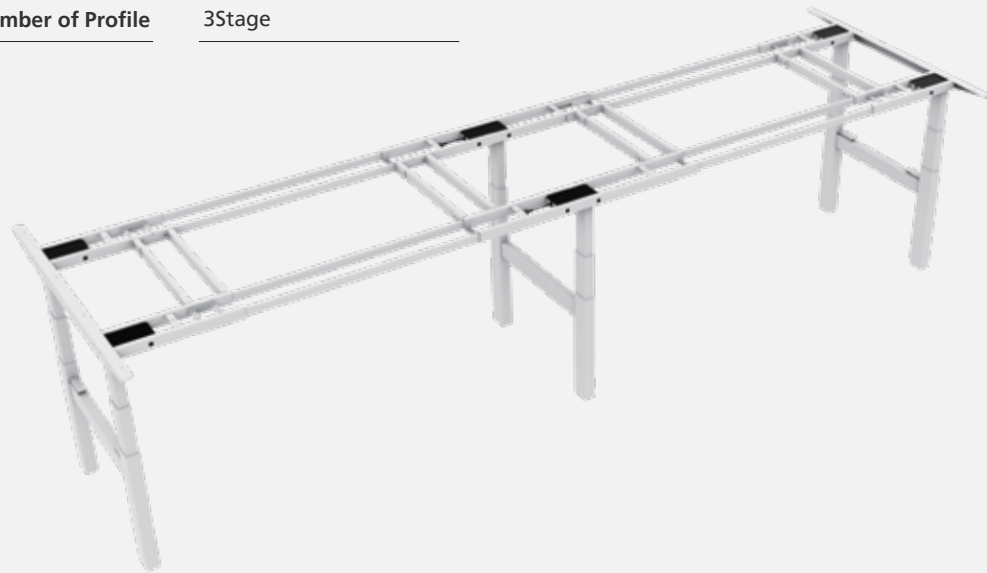

Single Column System

DS1



Multiple Column and Base Configurations



TV Stands

To expand the health benefits of a moving environment, OKIN's Height-Adjustable TV Stands bring the flexibility out of the desk. Our Electric Mobile TV Stands have a stronger steel frame that guarantees stability and mobility. Its smart design make it easy to assemble and can support a wide range of TV sizes.



Height-Adjustable TV Stand

Dual Column Electric Mobile TV Stand TDS2.151

Load Capacity	800N
Max Speed	25mm/s
Lifting range	920 ~ 1400mm
Suitable for TV sizes	55" ~ 75"



Dual Column Electric Mobile TV Stand TDS2.471

Load Capacity	1200N
Max Speed	35mm/s
Lifting range	800 ~ 1450mm
Suitable for TV sizes	55" ~ 90"



**Single Column Electric Mobile TV Stand
TDS1.452**

Load Capacity	800N
Max Speed	25mm/s
Lifting range	950 ~ 1450mm
Suitable for TV sizes	42" ~ 55"



Best-seller

**Single Column Hidden Cabinet Electric TV Stand
TDS1H.472**

Load Capacity	800N
Max Speed	25mm/s
Lifting range	810 ~ 1810mm
Suitable for TV sizes	40" ~ 55"



**Single Motor Ceiling TV Mount
TAS1**

Load Capacity	300N
Max Speed	15mm/s
Tilting range	0-85°
Suitable for TV sizes	32" ~ 75"



Lift Columns

With a straightforward and elegant design, OKIN's Lift Columns guarantee stability and a smooth movement when it is being operated. A wide range of configurations is offered and further customization to meet the customer needs is also available.

Colors



- Noise <48dB
- Anti-Collision
- Low Power Consumption



2 Stage

Load Capacity
800N

Max Speed
25mm/s

Height
Min: 650mm
Max: 1150mm

Stroke
500mm

DD471.2

TOP choice



DD452.2

TOP choice



DD441.2



DD451.2

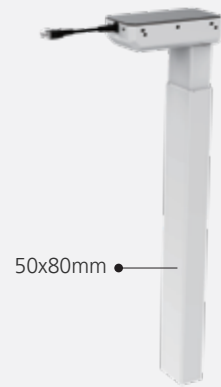

DD371.2

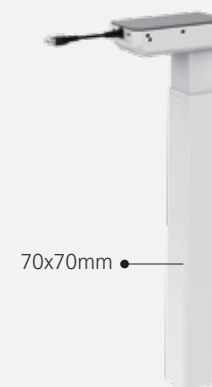

DD351.2

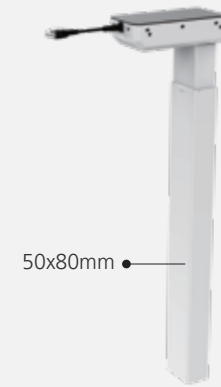

3 Stage

Load Capacity	800N
Max Speed	35mm/s
Height	Min: 560mm Max: 1210mm
Stroke	650mm

DD471.3

TOP choice

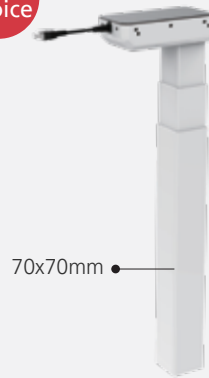

70x70mm

DD451.3

TOP choice

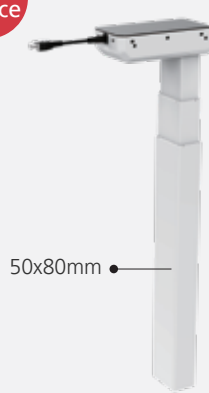

50x80mm

DD452.3

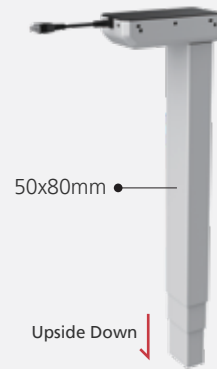

50x80mm

Upside Down ↓

DD472.3

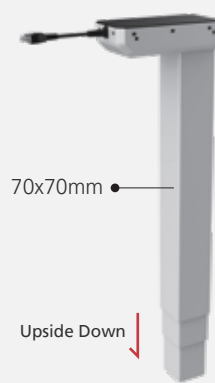

70x70mm

Upside Down ↓

DD442.3



∅ 70mm

Upside Down ↓

DD371.3

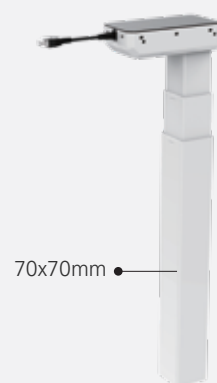

70x70mm

DD351.3



50x80mm

DD441.3



∅ 70mm

Inline

Load Capacity	800N
Max Speed	35mm/s
Height	Min: 520mm Max: 1170mm
Stroke	650mm

ID461.3

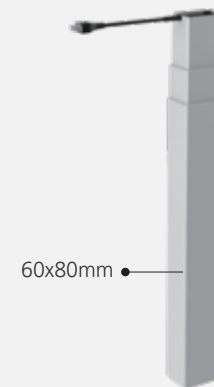

60x80mm



Control Units and Handsets

Ergonomic, user-friendly design meets a high-efficient transmission system to provide a wide range of modern and elegant Control Units that can be customized to meet the customer needs on request.



Control Units

DB02



Desk System	2-Column
Input	100-240V AC
Output	24V DC
Certifications	CB, UL, CE, SAA, PSE, KC
Standby Power	KC

DB03



Desk System	3-Column
Input	100-240V AC
Output	27V DC
Certifications	CB, UL, CE, SAA, PSE, KC
Standby Power	0.1W

MB02



Desk System	2-Column
Input	29V DC
Output	29V DC
Certifications	CB, UL, CE, SAA, PSE, KC
Standby Power	0.1W

NB02



Desk System	2-Column
Input	100-120V, 220-240V
Output	AC
Certifications	24V DC
Standby Power	CB, UL, CE, RCM, FCC

Handsets

DH01.01



DH01.02



DH01.03



DH01.15



DH01.16



DH01.18



DH02.01



DH02.03



DH02.04



DH01.25



DH03.01



 AB02



Handset with Built-In Control Box

Remote Controls

RC001



RC002



RC003



Accessories

To optimize the desktop, OKIN offers a dedicated range of functional and modern design accessories.
Customization available on request to better meet every customer requirements.



Wireless Charger

- 5W (5V / 1A) charging power
- USB ports available depending on the model
- Overvoltage, overcurrent and overheating protection



Cable Management

Cable Tray



Cable Chain

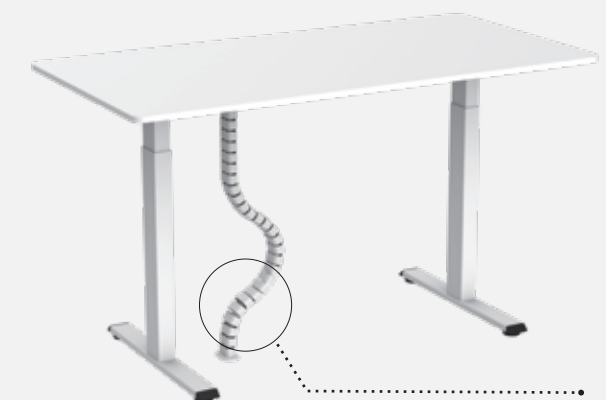

Length: max 1.3m

Power Supply

PW.10

Wall Mount SMPS



Input	100-240V AC 50Hz-60Hz 2.5A
Output	29V DC 1.5A/1.8A/2.0A
Plug	US, EU standards
Certifications	UL/FCC/IC/DOE/CEC/RoHS/CE/ERP/RoHS
	Overvoltage, overcurrent, overheating and short circuit protection

PW.20

Desktop SMPS



Input	100-240V AC 50HZ-60Hz 2.5A
Output	29V DC 1.8A/2.0A/3.0A
Plug	CHN, US, JP, EU, KOR, UK, AUS standards
Certifications	CCC/UL/FCC/IC/DOE/CEC/CB/CE/UKCA/PSE/KC+KCC/SAA+RCM/ERP/MEPS/RoHS
	Overvoltage, overcurrent, overheating and short circuit protection

PW.30

Desktop SMPS



Back up battery compartment
(2*9V batteries)

Input	100-240V AC 50Hz-60Hz 2.5A
Output	29V DC 18A/20A
Plug	CHN, US, JP, EU, KOR, UK, AUS standards
Certifications	CCC/UL/FCC/IC/DOE/CEC/CB/CE/UKCA/PSE/KC+KCC/SAA+RCM/ERP/MEPS/RoHS
	Overvoltage, overcurrent, overheating and short circuit protection

Shared Office

- Reserve shared working desks via APP or client website
- Reserve meeting rooms via APP or client website
- Manage user data, desk data and layout via backend platform
- Operate the desk to move upwards and downwards via personal APP



Wi-Fi / Bluetooth APP



Health Reminders

- Connect with individual or multiple desks (only with Wi-Fi App)
- Operate the desk to move upwards and downwards
- Reminder of suitable sit-stand time
- Set target for sitting and standing time
- Daily and weekly report for sit-stand time and calories

OKIN Global Service

China / Jiaxing

Add: No. 1507, Taoyuan Road, Gaozhao Street, Xiuzhou District, Jiaxing City, Zhejiang Province, China
Service Hotline: +86-400-887-8573
Tel: +86-(0)573-8228-1028
E-mail: sales@dewertokin-technology.com
Web: www.dewertokintechnology.com

China / Huizhou

Add: Dongfeng Car City Storage & Logistics Distribution Center, 5#, Longsheng Road No.2, Xinliao, Daya Bay District, Huizhou, Guangdong
Tel: +86-(0)755-8921-7192
E-mail: sam.shen@refinedchina.com

China / Taiwan

Phoenix Mecano Hong Kong Limited Taiwan Branch
Add: Room 4E-12, No.5, Hsin-Yi Road, Sec. 5, 11011 Taipei, Taiwan
Contact: Allen Wang - Sales Manager
Phone: +886 2 27252582
E-mail: allen@pmtwn.com.tw

Vietnam

Add: Lo H5-2(khu B1), duong D9, khu cong nghiep rach bap, xa an dien, thi xa ben cat, tinh binh duong, Vietnam
Contact: Peter Ruan
Mobile: +84 0919040713
Email: Peter.Ruan@dewertokin-technology.com

Germany

DewertOkin GmbH
Add: Weststrasse 1, 32278 Kirchlengern
Deutschland / Germany
Tel: +49 5223 979 0
Fax: +49 5223 751 82
E-mail: info@dewertokin.de
Web: http://www.dewertokin.com

Australia

Add: 64 Butler way, Tullamarine, Victoria, Australia, 3043
Tel: +61 (3) 9338 56 99
Fax: +61 (3) 9338 53 99
E-mail: info@phoenix-mecano.com.au
Web: www.phoenix-mecano.com.au

Korea

Add: No. 506, Bomb Building, 617-3, Gajeong-dong, Seo-gu, Incheon, Korea
Zip Code: 22731
Contact: Amos An
Mobile: +82-10-6865-0599
E-mail: amos.an@dewertokin-technology.com

Japan

Shizuoka Kinzoku Co., Ltd
Add: 52 Saiwai-Cho 420-0067 Shizuoka-City
Contact: JR Piao - Sales Manager
Mobile: +81-90-6507-0205
E-mail: jr.piao@dewertokin-technology.com
Web: https://www.dewertokin.com/ja/

Malaysia / India Singapore/ Thailand Indonesia

Add: No. 22A-1, Blok 22A, Level1, Empire Galleri, Jalan Empayar/KU1 off Persiaran Sultan Ibrahim, 41150 Klang, Selangor, Malaysia
Contact: Ngkian Seng
Mobile: +60 193150628
E-mail: ngks@dewertokin-technology.com

United States

Okin America INC.
Add: 291 CDF Blvd Shannon, MS 38868
Contact: Timothy Maillet
Tel: +1 616 5836393
E-mail: officeorders@okinamerica.com
Web: www.okinamerica.com

Brazil

DewertOkin Latin America
Add: Av. Prof. Alceu Maynard de Araujo, 185, São Paulo, SP
Zip Code: 04626-160
Contact: Mrs. Adriana Shinzato - Sales coordinator
Tel: +55 11 56434190
E-mail: vendas@dewertokin.com.br
Web: www.dewertokin.com.br

